

Question 16

A diffraction pattern is produced by a stream of electrons passing through a narrow slit, as shown in the diagram below.

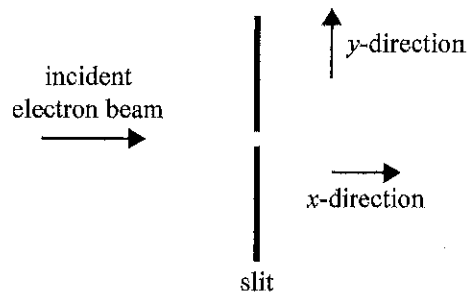

This electron diffraction pattern can be used to illustrate Heisenberg's uncertainty principle.

This is because knowing the uncertainty in the

- A. electron's speed is large leads to the uncertainty in its kinetic energy being small.
- B. slit width is small leads to a large uncertainty in the electron's momentum in the y-direction.
- C. electron's momentum in the y-direction is small leads to a large uncertainty in the slit's width.
- D. electron's angle of approach to the slit leads to a large uncertainty in the electron's momentum in the y-direction.

Question 17

Quantised energy levels within atoms can best be explained by

- A. electrons behaving as individual particles with varying energies.
- B. atoms having specific energy requirements that can only be satisfied by electrons.
- C. electrons behaving as waves, with each energy level representing a diffraction pattern.
- D. electrons behaving as waves, with only standing waves at particular wavelengths allowed.

Question 18 59%

Two students, Rob and Jan, measure the current in the same circuit on separate occasions.

Rob obtains the following readings: 9.50 mA, 9.21 mA, 9.10 mA and 9.60 mA (average 9.35).

Jan obtains the following readings: 9.20 mA, 9.25 mA, 9.31 mA and 9.36 mA (average 9.28).

The true value of the current is known to be 9.35 mA.

Which one of the following best describes these two sets of measurements?

- A. Rob's results are more accurate than Jan's results.
- B. Both sets of results are equally accurate.
- C. Rob's results are more precise than Jan's results.
- D. Both sets of results are equally precise.

Accuracy is difference between the mean and the actual value. Precision is the range between measurement.
(This is according to VCAA definitions which are wrong but we have to follow them)

✓ **Question 19**

Which one of the following best describes a hypothesis?

- A. a possible explanation that needs to be rigorously tested by experimental evidence
- B. an explanation that has been supported by rigorous experimental evidence
- C. a statement that is widely accepted by scientists
- D. an explanation that is mathematically correct

✓ **Question 20**

Which one of the following statements about systematic and random errors is correct?

- A. Random errors can be reduced by repeated readings.
- B. Both random and systematic errors can be reduced by repeated readings.
- C. Systematic errors can be reduced by repeated readings.
- D. Neither systematic nor random errors can be reduced by repeated readings.

Q9

- b. The students next investigate the relationship between various initial variables and range, R (on level ground), as shown in Figure 9. In this second experiment, they use a 0.10 kg ball and keep the catapult at a fixed angle of 30° during the experiment. The ball lands at the same height as it is fired.

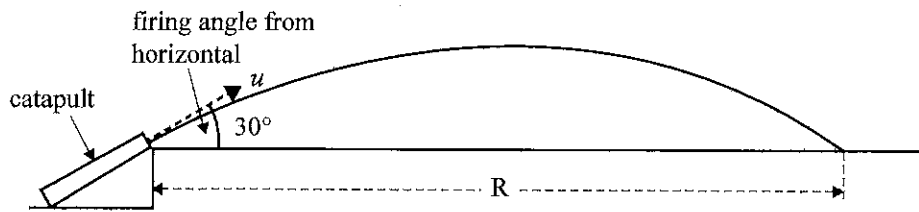

Figure 9

The variables in this experiment can be classified as controlled, dependent or independent.

Complete the table below by providing one variable from the experiment for each classification.

3 marks

57%

Classification	Variable
controlled	mass of the ball/angle of launch
dependent	range
independent	launch velocity

- c. The students gather the following data from a series of experiments similar to the one described in part b.

8 marks 43%

av. 6.5

$u = \text{initial speed (m s}^{-1}\text{)}$	$R = \text{range (m)}$
1.0	0.10
2.0	0.35
3.0	0.78
4.0	1.40
5.0	2.15

The students use a tape measure that is marked with intervals of 10 cm to measure the range that the ball travels at different initial speeds.

On the grid provided below:

- graph the data gathered by the students (from the table on page 24)
- include scales and units on each axis
- insert appropriate uncertainty bars for the range (distance) on the graph
- draw a smooth curve of best fit.

8 marks

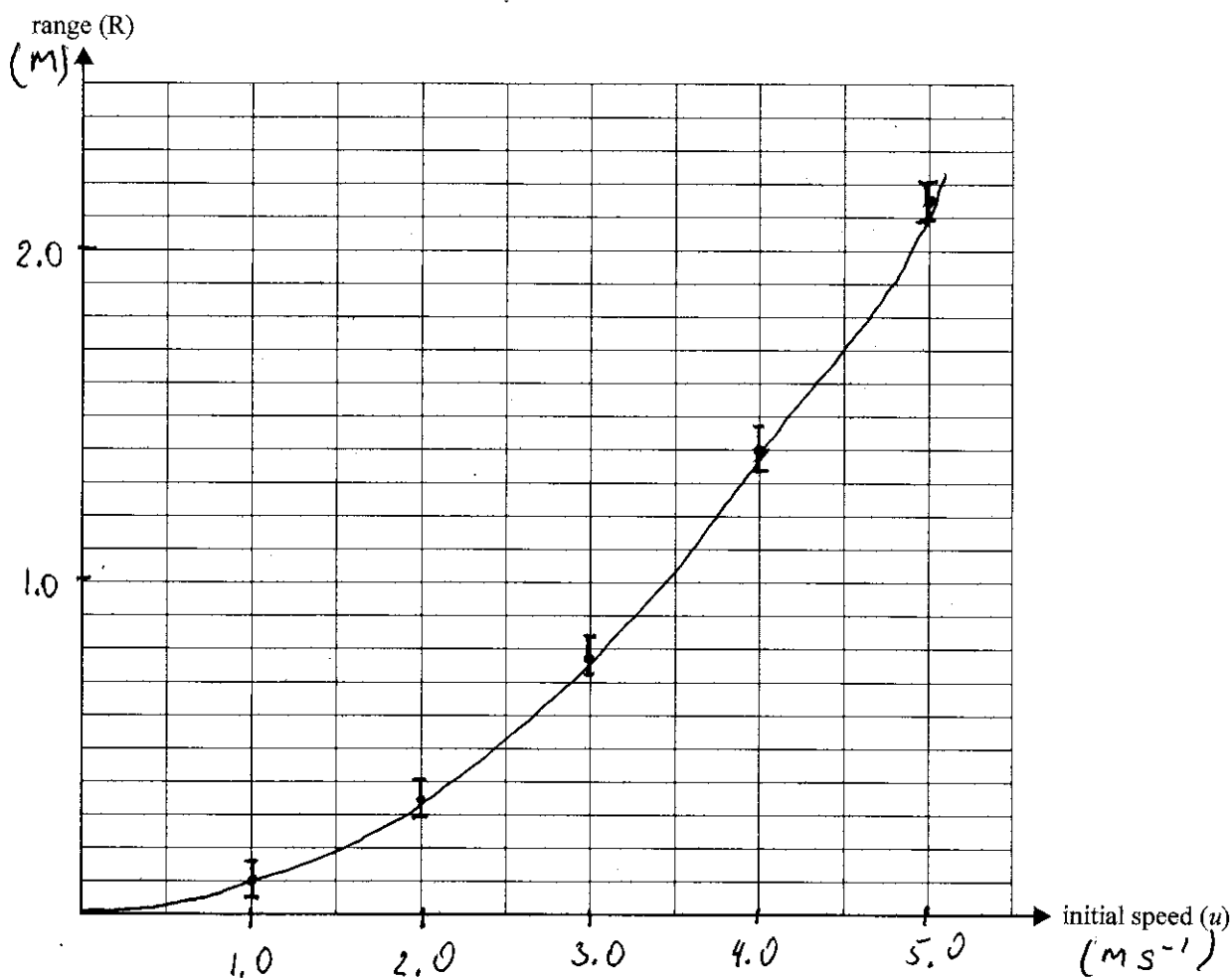

Scales - 1

Units - 1

Smooth curve - 1

Through the origin - 1

Correct points, correct uncertainty bars

SECTION B - continued
TURN OVER

Question 16

When light of a specific frequency strikes a particular metal surface, photoelectrons are emitted.

If the light intensity is increased but the frequency of the light remains the same, which of the following is correct?

	Number of photoelectrons emitted	Maximum kinetic energy of the photoelectrons
A.	remains the same	remains the same
B.	remains the same	increases
C.	increases	remains the same
D.	increases	increases

Question 17

A metal surface has a work function of 2.0 eV.

The minimum energy of an incoming photon required to eject a photoelectron is

- A. 3.2×10^{-19} J
- B. 1.6×10^{-19} J
- C. 8.0×10^{-20} J
- D. 4.0×10^{-20} J

Question 18

A student measures a very small current in a circuit and obtains the result 0.000670 A.

The number of significant figures in the measurement 0.000670 A is

- A. 2
- B. 3
- C. 5
- D. 6

Rules for significant figures

Question 19

An independent variable is best described as one that is

- A. set by the researcher.
- B. not relevant to the experiment.
- C. fixed throughout the experiment.
- D. not related to any other variables in the experiment.

Question 20

The main reason for repeating an experiment is to

- A. reduce random error.
- B. reduce systematic error.
- C. allow for differences between researchers.
- D. allow for variations in controlled variables.

All other doesn't make sense.

Question 10 (11 marks)

Two VCE Physics students, Laura and Hal, are investigating Snell's law.

They set up their apparatus to measure the refraction of a beam of red laser light going from air into a semicircular plastic block, as shown in Figure 8.

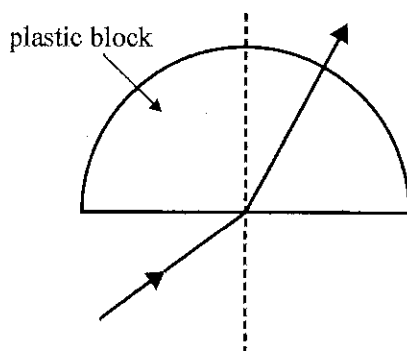

Figure 8

Using this one block, they vary the angle of incidence and measure the resulting angles of refraction.

- a. List the variables involved in this experiment and classify them as controlled, dependent or independent variables. Include one of each type of variable in the table provided below.

2 marks

Variable	Classification
Incident angle	Independent
Refracted angle	dependent
refractive index of the block or frequency/wavelength of the light	controlled

- b. Laura and Hal record the data shown in the table below.

Angle of incidence, i (degrees)	$\sin i$	Uncertainty in $\sin i$	Angle of refraction, r (degrees)	$\sin r$	Uncertainty in $\sin r$
5	0.09	± 0.04	3.0	0.052	± 0.04
10	0.17	± 0.04	6.6	0.12	± 0.04
15	0.26	± 0.04	9.9	0.17	± 0.04
20	0.34	± 0.04	13.3	0.23	± 0.04
25	0.42	± 0.04	16.4	0.28	± 0.04

Using the data in the table on page 22, on the axes below:

- plot $\sin r$ versus $\sin i$
- draw in uncertainty bars in both the x and y directions for each data point
- draw a line of best fit.

Include labels and scales for both axes.

6 marks

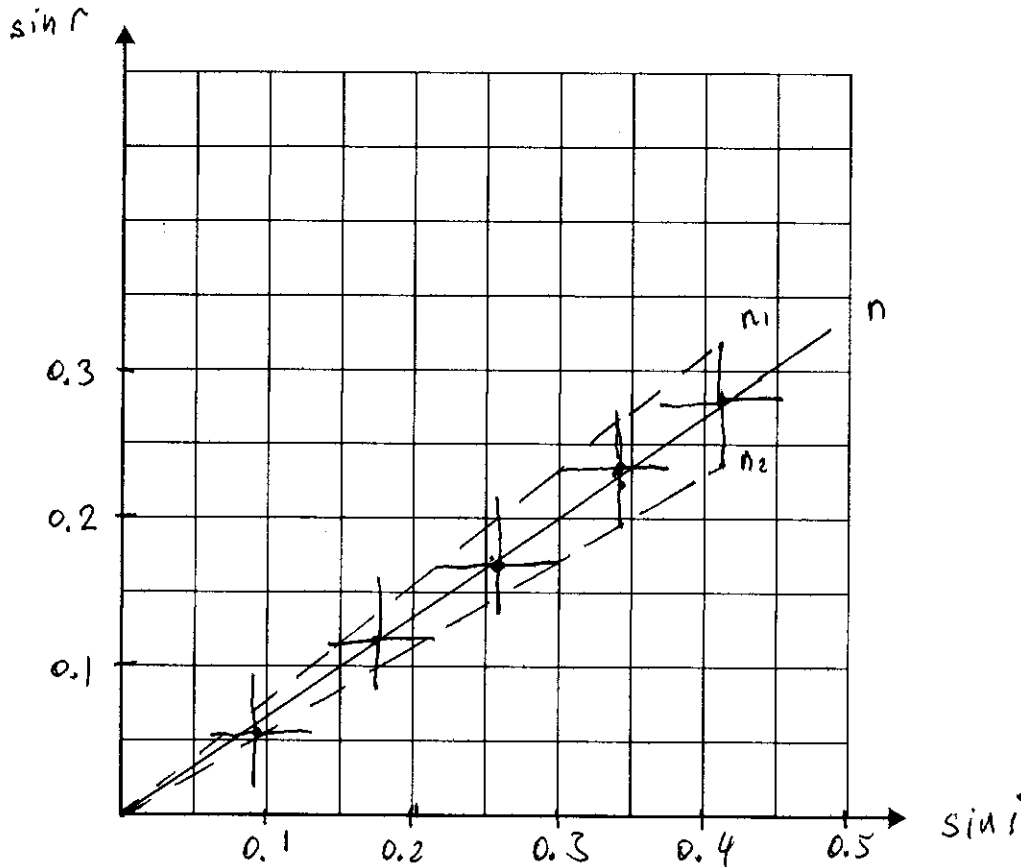

- c. From the graph created in **part b.**, determine the value of the refractive index of the plastic material of the block. Give your answer to an appropriate number of significant figures.

3 marks

$$n = \frac{0.45}{0.3} = 1.5$$

$$n_1 = \frac{0.25}{0.19} = 1.3$$

$$n_2 = \frac{0.35}{0.21} = 1.7$$

1.5 ± 0.2

↑
Did not required

Did not required

Question 17

The results of a photoelectric experiment are displayed in the graph below. The graph shows the maximum kinetic energy ($E_{k,max}$) of photoelectrons versus the frequency (f) of light falling on the metal surface.

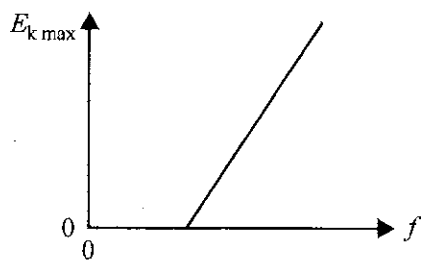

A second experiment is conducted with the original metal surface being replaced by one with a larger work function. The original data is shown with a solid line and the results of the second experiment are shown with a dashed line. Which one of the following graphs shows the results from the second experiment?

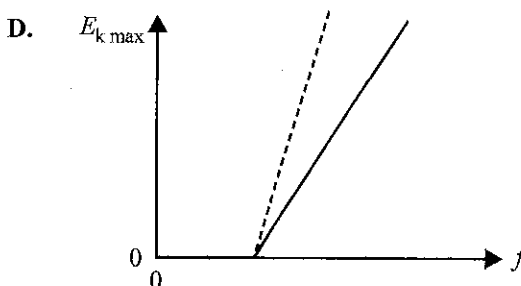
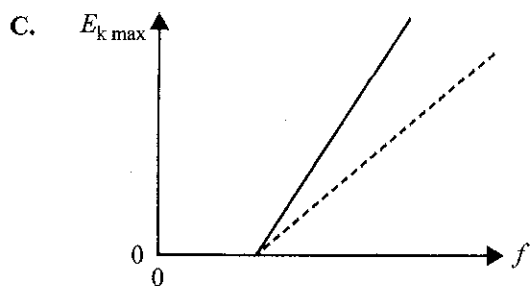
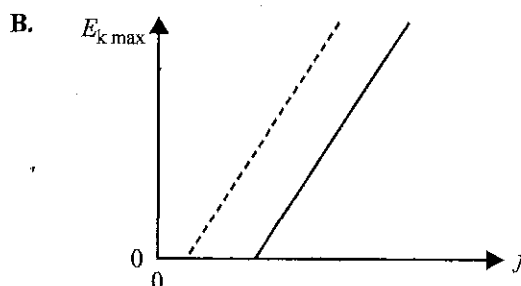
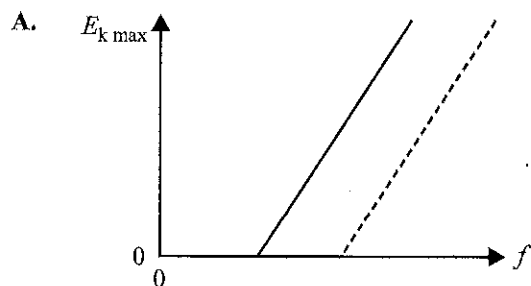
**Question 18**

57%

The experimental uncertainty in a measurement of any particular quantity is **best** described as

- A. a quantitative estimate of the doubt associated with the measurement.
- B. the degree of confidence a scientist has in their experimental technique.
- C. the difference between the measurement and the true value of the quantity.
- D. the result of one measurement; repeated measurements can eliminate uncertainty.

Question 19 70%

The diagram below shows a properly calibrated ammeter with its pointer registering a current of close to 3 A.

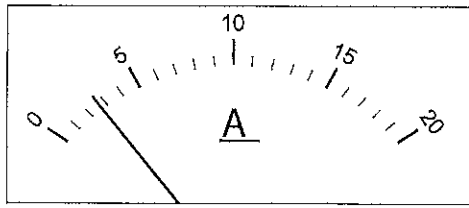

Which one of the following is the most appropriate measure of the uncertainty of this pointer reading?

- A. 0.05 A
- B. 0.5 A
- C. 0.8 A
- D. 1 A

Question 20 82%

A group of Physics students conducts a controlled experiment to investigate the phenomenon of electromagnetic induction. The students place a coil within a uniform magnetic field, as shown in the diagram below.

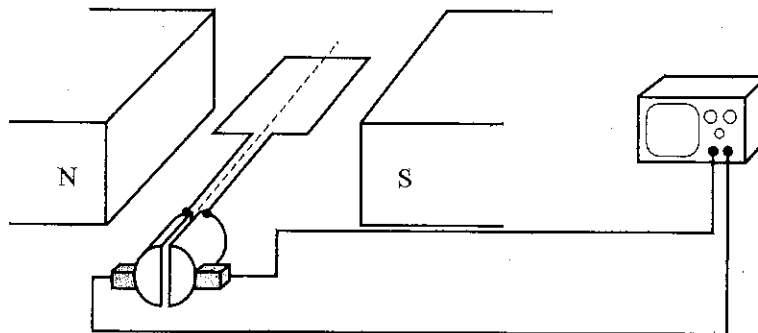

The coil is spun at 50 revolutions per minute, 100 revolutions per minute and then 150 revolutions per minute, and the peak EMF is measured each time on an oscilloscope.

Which of the following **best** identifies the independent and dependent variables, and a possible controlled variable in this experiment?

	Independent variable	Dependent variable	Controlled variable
A.	speed of rotation	strength of magnetic field	peak EMF
<input checked="" type="radio"/> B.	speed of rotation	peak EMF	strength of magnetic field
C.	peak EMF	speed of rotation	strength of magnetic field
D.	peak EMF	strength of magnetic field	speed of rotation

END OF SECTION A

Question 20 (10 marks) *5 marks - 68% av 4.3*

Some students have collected data on the orbital period, T , and orbital radius, R , of five of Saturn's moons. The results are shown in the table below. Assume that the moons are in circular orbits.

Moon	Orbital period (s)	Orbital radius (m)	T^2 (10^{10} s^2)	R^3 (10^{24} m^3)
Mimas	8.14×10^4	1.86×10^8	0.66	6.40
Enceladus	1.18×10^5	2.38×10^8	1.39	13.5
Tethys	1.63×10^5	2.95×10^8	2.66	25.7
Dione	2.36×10^5	3.77×10^8	5.57	53.6
Rhea	3.90×10^5	5.27×10^8	15.2	146

- a. On the axes provided below:
- plot a graph of the observational data T^2 versus R^3
 - include a scale on each axis
 - draw a line of best fit.

5 marks

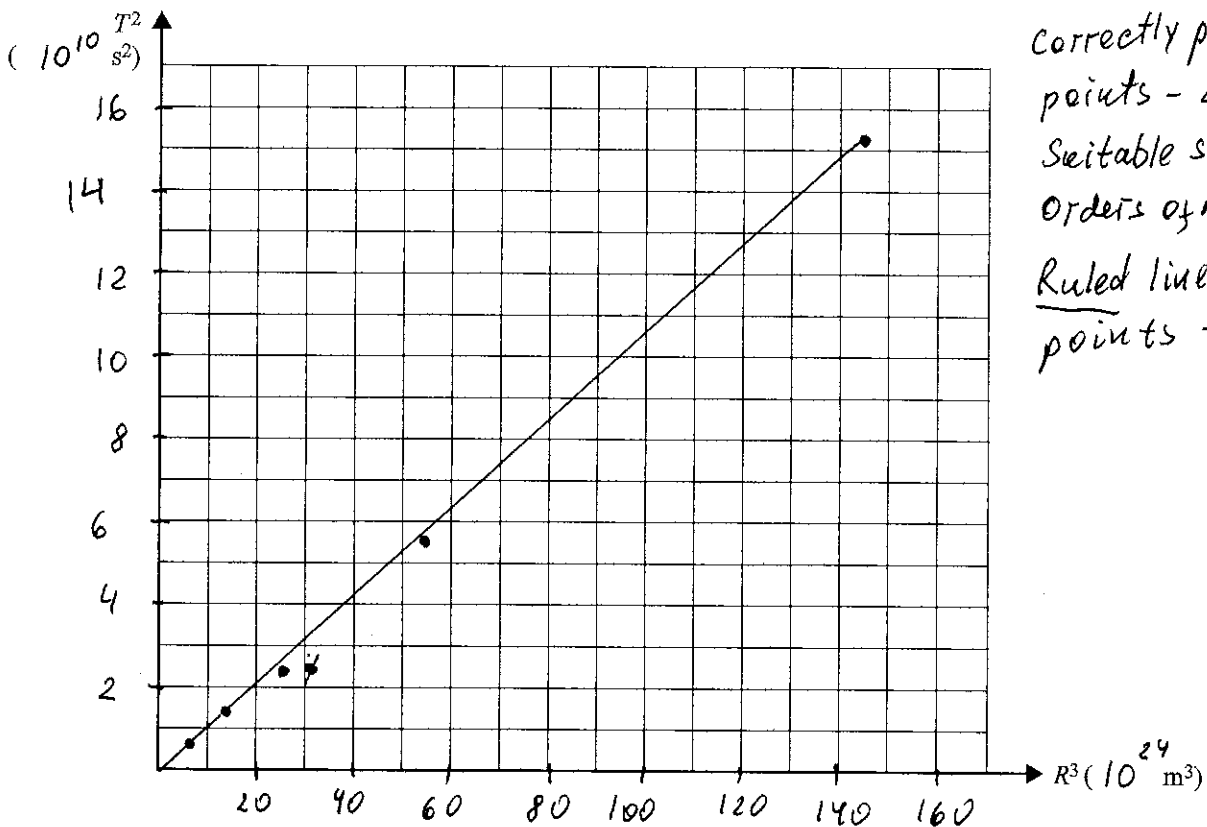

*Correctly plotted points - 2
 Suitable scales - 1
 Orders of magnitude;
 Ruled line through points - 1*

- b. Calculate the gradient of the line of best fit drawn in **part a**. Show your working.

37%

2 marks

$$\frac{(9.5-1) \times 10^{10}}{(40-10) \times 10^{24}} = 1.06 \times 10^{-15}$$

$$\boxed{9.9 \times 10^{-16} - 1.1 \times 10^{-15} \text{ s}^2 \text{ m}^{-3}} \quad \text{Accepted interval}$$

- c. Use the value of the gradient calculated in **part b**. to determine the mass of Saturn. Show your working.

34%

3 marks

$$\frac{T^2}{r^3} = \frac{4\pi^2}{GM}$$

$$-1.06 \times 10^{-15} = \frac{4\pi^2}{6.67 \times 10^{-11} M_s}$$

must use answer from b)

$$M_s = \frac{4\pi^2}{6.67 \times 10^{-11} \times 1.06 \times 10^{-15}}$$

$$\boxed{5.6 \times 10^{20} \text{ kg}}$$

Question 8 (15 marks)

Students are investigating the forces involved in horizontal circular motion. Their apparatus consists of a model car that travels in a circle at constant speed. The speed of the model car can be set at different values. The car is connected by a string of length 1.0 m to the centre of the circle. Incorporated in the string is a sensor that measures the tension (force) of the string. There is no radial friction force between the car's tyres and the surface that the car moves on.

Figure 9 shows the experimental arrangement viewed from above.

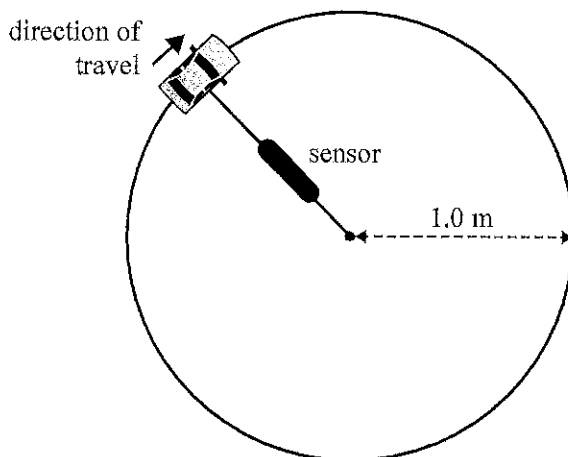

Figure 9

The students obtain a number of measurements by varying the setting for the period of rotation, T , and then recording the force, F_T , in the string. They know T with great accuracy but the sensor has an experimental uncertainty of ± 0.4 N.

- a. What is experimental uncertainty and how can it be reduced? 2 marks

Uncertainty is the margin for error in a measurement.
Can be reduced by repeated measurement.
 (Wrong statement, but this is what VCAA wants)
(Should be - use a more precise measurement device).
Best - write both.

- b. Identify the independent variable, the dependent variable and two controlled variables involved in this experiment. 3 marks

Independent variable Period or speed of the car

Dependent variable Force

Controlled variable 1 Mass of the car

Controlled variable 2 Length of the string

- c. i. The students have recorded the data for the period of rotation, T , and the force, F_T , in the table below. The radius of the circle is 1.0 m.

Calculate the values of $1/T^2$ and write them in the table below.

1 mark

Period T (s)	$1/T^2$ (s^{-2})	Force F_T (N)
5.00	0.04	8
10.0	0.01	2
15.0	4.4×10^{-3}	0.9
20.0	2.5×10^{-3}	0.5

- ii. The relationship between F_T and T is given by the formula

$$F_T = \frac{4\pi^2 mr}{T^2}$$

On the axes provided below:

- plot a graph of F_T versus $1/T^2$ using the data in the table in **part c.i.**
- include the correct uncertainty bars for the F_T values
- label each of the axes correctly
- draw a line of best fit.

6 marks

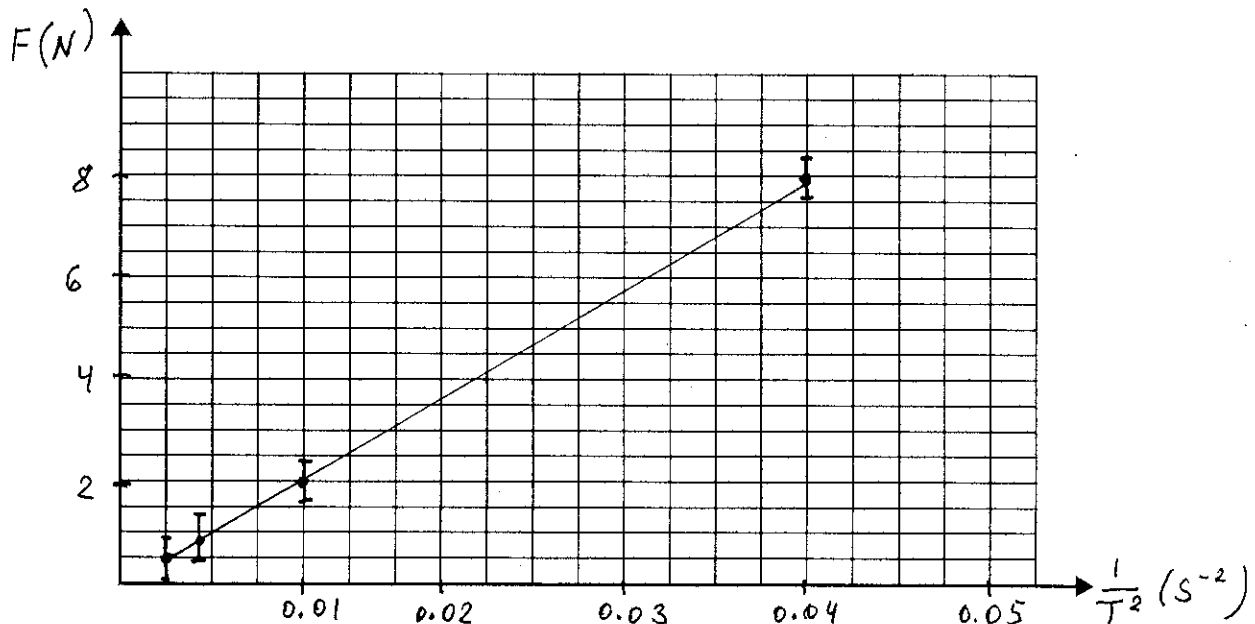

- d. Using the line of best fit and the formula from **part c.ii.**, determine the value of m , the mass of the car. Show your working.

3 marks

$$m = \frac{1}{4\pi^2 r} \left(\frac{F}{1/T^2} \right) - \text{gradient}$$

$$\text{Gradient} = \frac{8 - 0.5}{0.04 - 0.0025} = 200$$

5.1 kg

Question 16

Students are conducting a photoelectric effect experiment. They shine light of known frequency onto a metal and measure the maximum kinetic energy of the emitted photoelectrons.

The students increase the intensity of the incident light.

The effect of this increase would most likely be

- A. lower maximum kinetic energy of the emitted photoelectrons.
- B. higher maximum kinetic energy of the emitted photoelectrons.
- C. fewer emitted photoelectrons but of higher maximum kinetic energy.
- D. more emitted photoelectrons but of the same maximum kinetic energy.

Question 17

Which one of the following is true when incandescent light is compared to laser light?

- A. Laser light has a very wide spectrum; incandescent light has a very narrow spectrum.
- B. Both laser light and incandescent light have a very narrow spectrum.
- C. Laser light is incoherent; incandescent light is coherent.
- D. Laser light is coherent; incandescent light is incoherent.

✓ Use the following information to answer Questions 18 and 19.

As part of an experimental investigation, Physics students use a pendulum, as shown below, to indirectly measure the magnitude of Earth's gravitational field at their location.

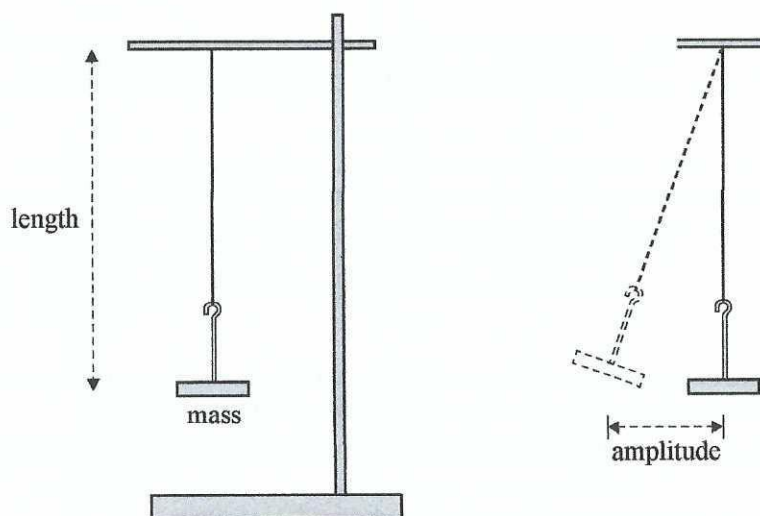

The students use a constant mass and a constant amplitude of swing, changing only the length of the pendulum and then measuring the time for five oscillations. They obtain four different time readings for four different lengths of the pendulum.

By using the relationship

$$T = 2\pi \sqrt{\frac{l}{g}}$$

where T is the period and l is the length of the pendulum, the students obtain four values for the magnitude of Earth's gravitational field.

✓ Question 18 83%

Which of the following best identifies the independent, dependent and controlled variables in the students' experimental investigation?

	Independent	Dependent	Controlled
A.	length	time	mass, amplitude
B.	time	length	mass, amplitude
C.	mass	time	length, amplitude
D.	amplitude	length	time, mass

✓ Question 19 85%

Which one of the following best explains why the students measured the time for five oscillations rather than the time for one oscillation?

- A. One oscillation is too quick to see.
 B. Five oscillations reduce the effect of air friction.
 C. Five oscillations reduce the uncertainty of the measured period.
 D. Five oscillations reduce the uncertainty of the measured length.

✓ Question 20 36%

As part of their Physics course, Anna, Bianca, Chris and Danshirou investigate the physics of car crashes. On an internet site that describes what happens during car crashes, they find the following statement.

It happens in a flash: your car goes from driving to impacting ... As the vehicle crashes into something, it stops or slows very abruptly, and at the point of impact the car's structure will bend or break. That crumpling action works to absorb some of the initial crash forces, protecting the passenger compartment to some degree.

Source: Kathleen Poling, 'Crash Dynamics for Dummies', Car Seats for the Littles, 3 January 2018, <<https://csfil.org/crash-dynamics-dummies/>>

The students disagree about the use of the word 'forces' in the statement, 'That crumpling action works to absorb some of the initial crash forces, protecting the passenger compartment to some degree'.

Which one of the following students best identifies the physics of how the crumpling action protects the passengers?

A.	Anna	'... to absorb some of the initial crash speed, protecting ...'
B.	Bianca	'... to absorb some of the initial crash kinetic energy, protecting ...'
C.	Chris	'... to absorb some of the initial crash momentum, protecting ...'
D.	Danshirou	'... to absorb some of the initial crash forces, protecting ...'

END OF SECTION A
TURN OVER

✓ Question 19 (18 marks)

As part of their practical investigation, some students investigate a spring system consisting of two springs, A and B, and a top platform, as shown in Figure 20. The students place various masses on the top platform. Assume that the top platform has negligible mass.

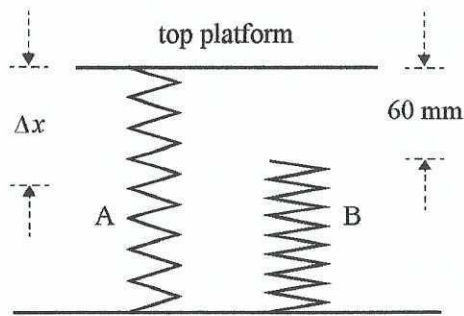

Figure 20

With no masses on the top platform of the spring system, the distance between the uncompressed Spring A and the top of Spring B is 60 mm.

The students place various masses on the top platform of the spring system and note the vertical compression, Δx , of the spring system.

They use a ruler with millimetre gradations to take readings of the compression of the spring(s), Δx , with an uncertainty of ± 2 mm.

The results of their investigation are shown in Table 1 below.

Table 1

Mass (g)	Compression, Δx (mm)
0	0
300	21
600	40
900	60
1300	68
1700	75
1900	80

The students plot a force (F) versus compression (Δx) graph for the spring system and use $g = 10 \text{ N kg}^{-1}$ for the value of the magnitude of the gravitational field strength.

√a. On the axes provided below:

- plot a graph of force (F) versus compression (Δx) for the spring system
- include scales and units on each axis
- insert appropriate uncertainty bars for the compression values on the graph
- draw lines that best fit the data for:
 - the effect of Spring A alone
 - the effect of Spring A and Spring B.

17%

6 marks

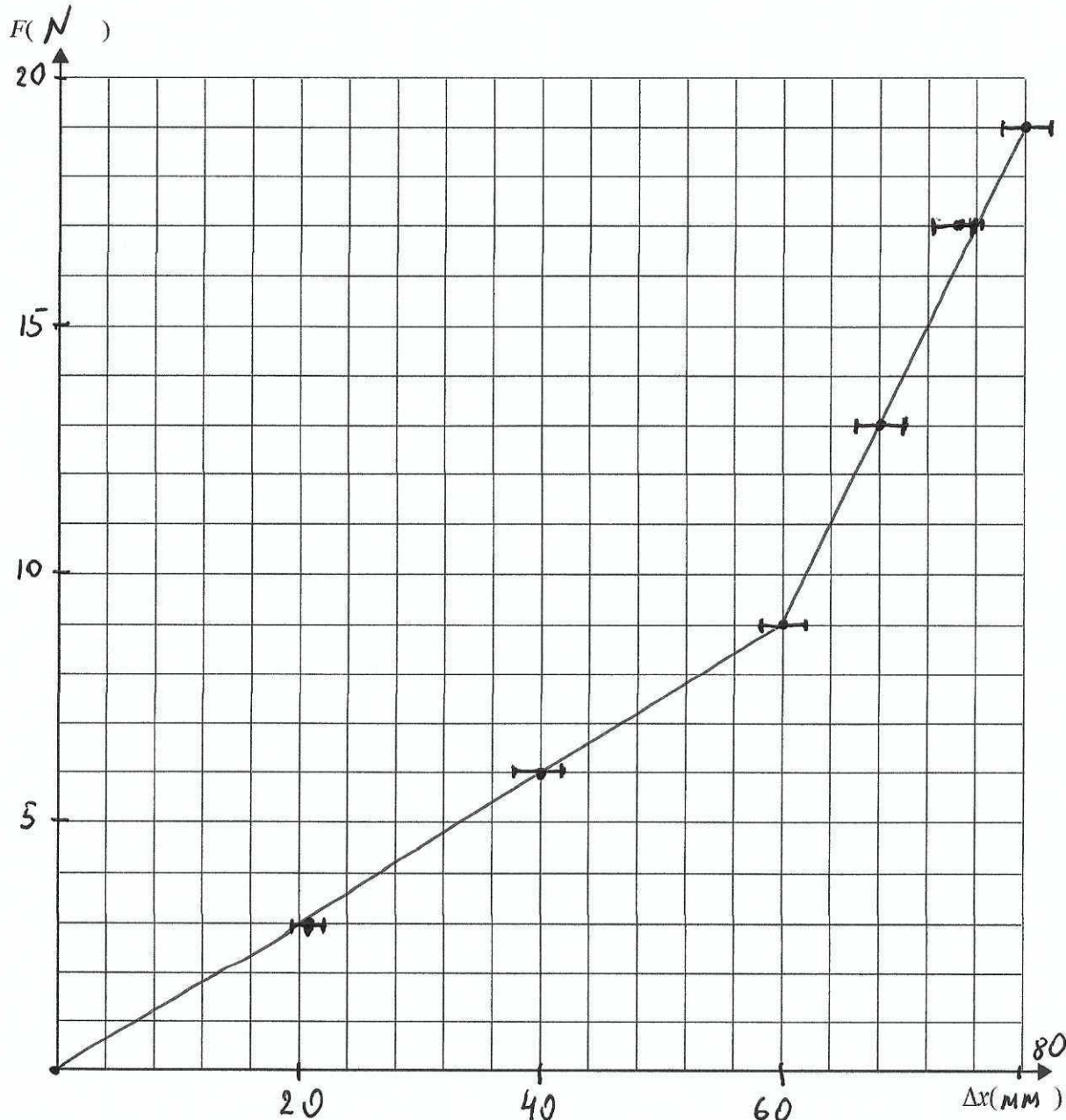

Scales 1 m ($\geq 50\%$ of axes)

Units 1 m

Points 2 m

Error bars 1 m

2 straight lines 1 m

SECTION B – Question 19 – continued

TURN OVER

- ✓ b. i. Determine the spring constant for Spring A, k_A . Show your working.

2 marks

$$k_A = \frac{F}{\Delta x} = \frac{9}{0.06} = 150$$

35%

$$150 \text{ N m}^{-1}$$

- ii. Determine the spring constant for Spring B, k_B . Show your working.

2 marks

Combined springs in II. $K = k_A + k_B$

14%

$$k = \frac{F}{\Delta x} = \frac{100}{0.02} = 500 \text{ N m}^{-1}$$

$$350 \text{ N m}^{-1}$$

$$k_B = 500 - 150$$

c. Using the area under the force (F) versus compression (Δx) graph, or otherwise, determine

- ✓ i. the potential energy (PE_A) stored in Spring A when the spring system is compressed by 80 mm. Show your working

2 marks

$$E = \frac{1}{2} kx^2 = \frac{1}{2} 150 \times 0.08^2$$

41%

0.48 J

- ✓ ii. the potential energy (PE_{A+B}) stored in the spring system when the spring system is compressed by 80 mm. Show your working

2 marks

Total area under the graph or

$$\frac{1}{2} \times 9 \times 0.06 + \frac{1}{2} \times 10 \times 0.02 + 9 \times 0.02$$

15%

0.55 J

- ✓ iii. the work done to compress Spring B when the spring system is compressed by 80 mm. Show your working.

2 marks

$$P_B = P_{A+B} - P_A$$

$$= 0.55 - 0.48$$

21%

0.07 J

- ✓ d. Explain how this type of spring system could be used in car spring suspension systems to enable the car to negotiate small bumps and more severe bumps in the road.

2 marks

First spring provides suspension for small bumps. 36%

Double spring - for severe bumps.

Question 19 84%

Which one of the following best describes a hypothesis?

- A. a testable scientific explanation
- B. a well-tested scientific explanation
- C. a scientific explanation by a famous scientist
- D. a widely believed and highly plausible explanation

END OF SECTION A

Question 18 (16 marks)

Students are modelling the effect of the resistance of electrical cables, r , on the transmission of electrical power. They model the cables using the circuit shown in Figure 18.

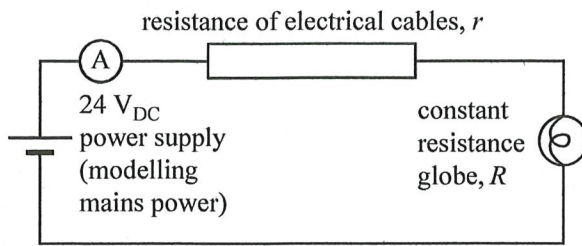
**Figure 18**

- a. The 24 V_{DC} power supply models the mains power.

Describe the effect of increasing the resistance of the electrical cables, r , on the brightness of the constant resistance globe, R .

2 marks

Current will decrease so brightness will decrease 63%

The students investigate the effect of changing r by measuring the current in the electrical cables for a range of values. Their results are shown in Table 1 below.

Table 1

Resistance of cables, r (Ω)	Current in cables, i (A)	$\frac{1}{i}$ (A^{-1})
2.4	2.4	0.42
3.6	2.0	0.50
6.4	1.7	0.59
7.6	1.5	0.67
10.4	1.3	0.77

- b. Identify the dependent and the independent variables in this experiment. Give your reasoning.

2 marks

Independent - resistance of the cables

58%

Dependent - current in the cable

- c. To analyse the data, the students use the following equation to calculate the resistance of the cables for the circuit.

$$r = \frac{24}{i} - R$$

Show that this equation is true for the circuit shown in Figure 18. Show your working.

2 marks

$$V = R_{\text{total}} i = (R + r) i$$

35%

$$r i = V - R i$$

$$r = \frac{24}{i} - R$$

- d. Calculate the values of $\frac{1}{i}$ and write them in the spaces provided in the last column of Table 1.

2 marks

87%

SECTION B – Question 18 – continued
TURN OVER

e. Plot a graph of r on the y -axis against $\frac{1}{i}$ on the x -axis on the grid provided below. On your graph:

- choose an appropriate scale and numbers for the x -axis
- draw a straight line of best fit through the plotted points
- include uncertainty bars ($\pm x$ -direction only) of $\pm 0.02 \text{ A}^{-1}$. (Uncertainty bars in the y -direction are not required.)

1 mark - more than 20% of grid used
1 mark numbers on x-axis 2 marks - points 1 mark - 50% uncertainty bars 1 mark - line of best fit

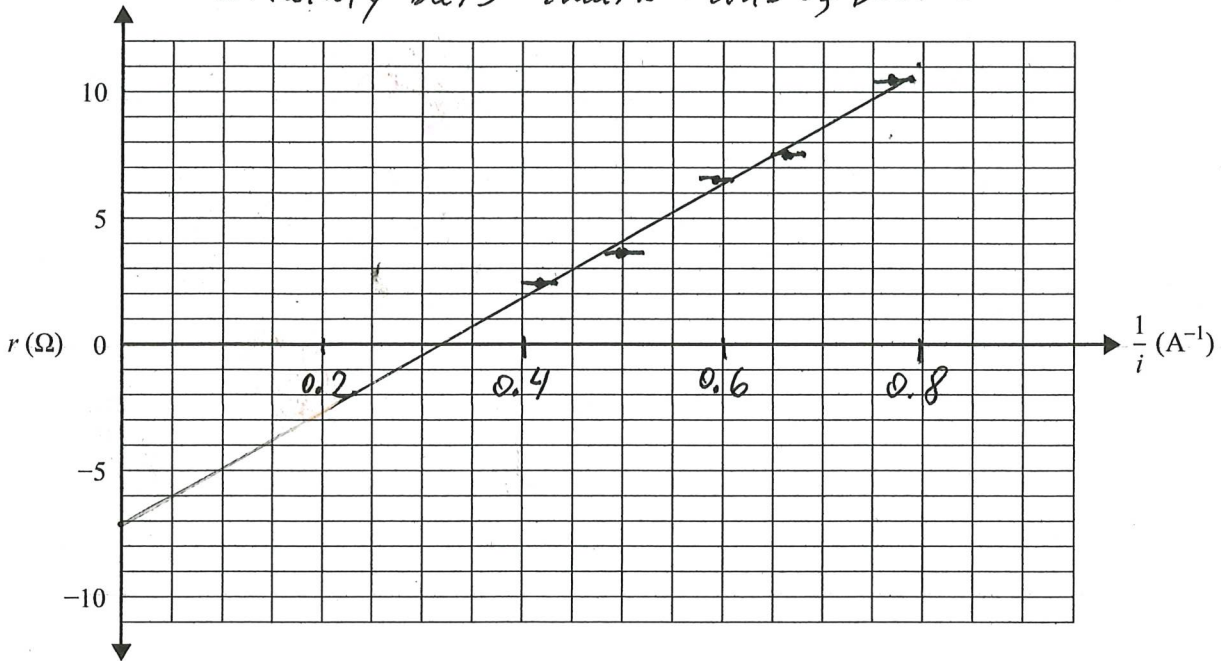

f. Use the straight line of best fit to find the value of the constant resistance globe, R . Give your reasoning.

2 marks
31%

R is a y-intercept $R = 7 \Omega$

7 Ω

Question 19

In an experimental investigation, an independent variable is one that is

- A. independent of the investigator's control.
- B. a value selected by the investigator.
- C. fixed throughout the experiment.
- D. the key variable to be measured.

Question 18 (15 marks)

A small rubber ball of mass 50 g falls vertically from a given height and rebounds from a hard floor. The ball's speed immediately before impact is 3.6 m s^{-1} . The ball rebounds upward at a speed of 3.3 m s^{-1} immediately after it leaves the floor. The ball is in contact with the floor for 40 ms.

- a. Calculate the magnitude and direction of the net average force acting on the 50 g ball while it is in contact with the floor. Show your working. 4 marks

$$Ft = \Delta p \quad \Delta p = p - p_0 = 0.05 \times 3.3 - (-0.05 \times 3.6)$$

$$= 0.05 \times 6.9 = 0.345$$

$$F = \frac{\Delta p}{t} = \frac{0.345}{0.04} = 8.625$$

8.6 N	Up
-------	----

- b. Just before the ball hits the floor, it has a certain amount of kinetic energy, E_k . At one instant when the ball is in contact with the floor, it is stationary before it rebounds.

Explain what has happened to the kinetic energy, E_k , of the ball when it is stationary. 2 marks

Some lost to heat and sound,
some converted in the elastic potential energy
of deformed ball.

- c. Just before the ball hits the floor, it has a certain amount of vertical momentum, p . At one instant when the ball is in contact with the floor, it is stationary before it rebounds.

What has happened to the vertical momentum, p , of the ball when it is stationary? 1 mark

Momentum transferred to Earth.

During their practical investigation, some Physics students investigate the movement of a small rubber ball. The ball falls from a height of 1.00 m and rebounds to a height of 0.78 m. The students record the ball's vertical position versus time by using a smartphone's video feature and a metre rule scale.

The uncertainty in the ball's vertical position is ± 0.03 m. The results from the students' recorded data are plotted on the graph in Figure 21.

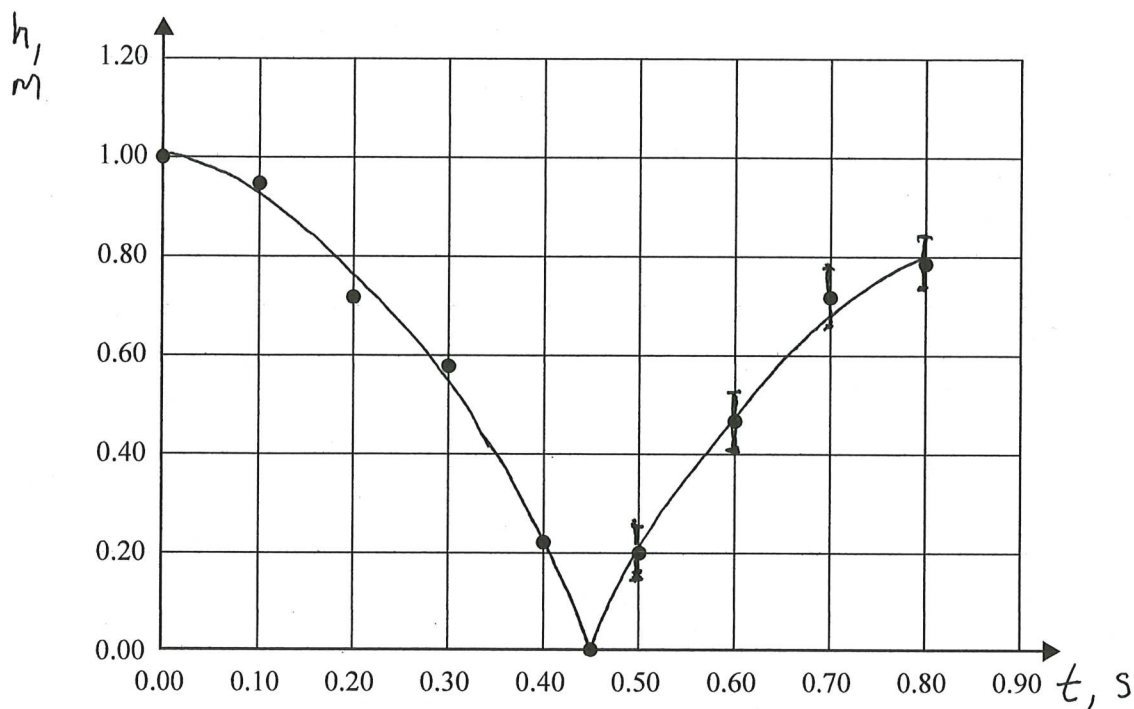

Figure 21

d. On the graph in Figure 21:

- label each axis and include units on each axis
- insert appropriate uncertainty bars for the height values on the graph, for the readings for the first four data points after the ball is released
- draw smooth curves of best fit.

5 marks

e. Estimate the speed of the ball at the instant of impact using an appropriate gradient of the graph in Figure 21. Use calculations to support your answer.

3 marks

$$v \text{ is the gradient} = \frac{0.22 - 0}{0.45 - 0.4} = 4.4 \text{ m s}^{-1}$$

m s⁻¹

END OF QUESTION AND ANSWER BOOK