

Magnetic field Worksheet

1. Determine the direction of the magnetic field for each of the following 4 wires.

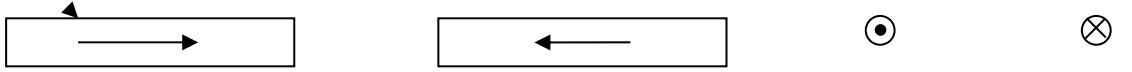

2. Determine the orientation of the magnetic field for each of the following 3 coils.

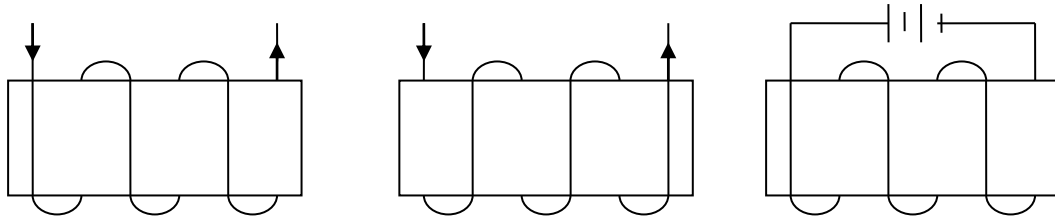

3. Draw an arrow in the "compass" circles to designate the direction of the magnetic field at those locations near the permanent magnets:

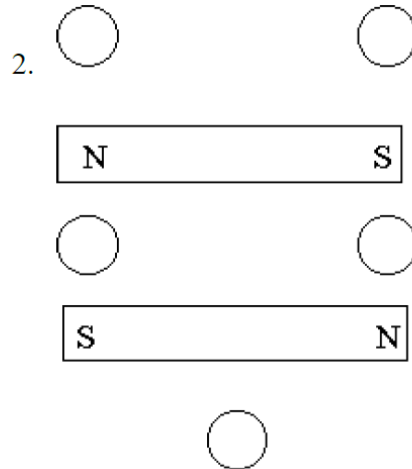
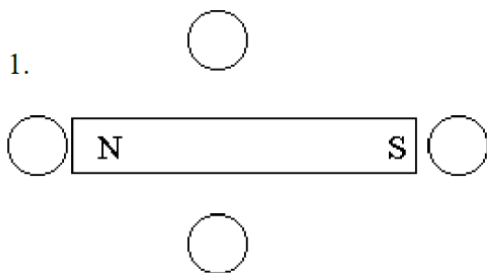

4. Draw an arrow (or dot, or X) in the "compass" circles to designate the direction of the magnetic field at those locations near these moving charges and current-carrying wires (use right hand rule #1). Let circles with a dot in them represent direction out of the page and circles with an X in them represent direction into the page:

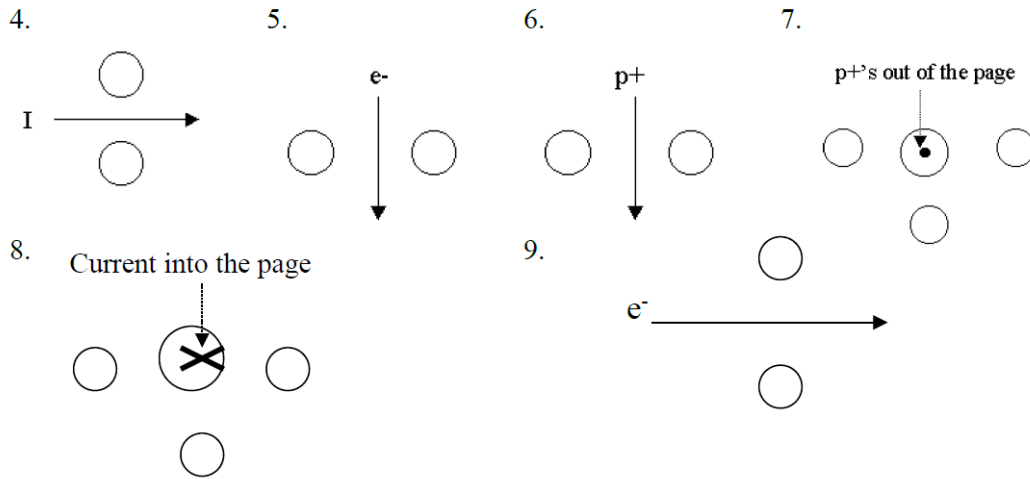

5. Using arrows, X's or dots, indicate the requested variable for each questions using the right hand rules.

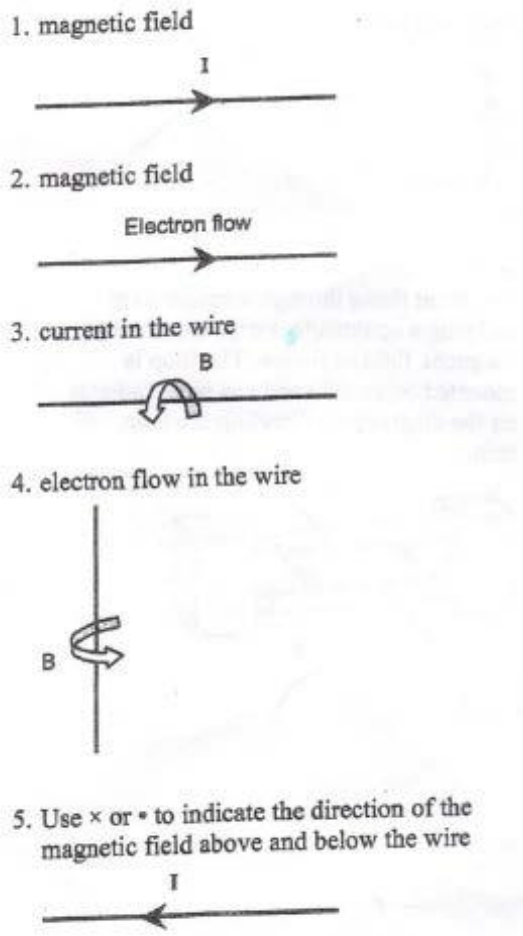

6. Two bar magnets are arranged as shown. Draw the direction of the magnetic field at point P.

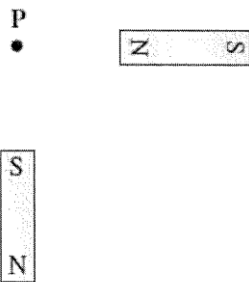

7. A piece of iron is wrapped with current carrying wire. Label the north and south poles on the piece of wire.

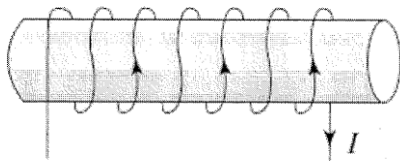

8. A compass is wrapped with coils of current carrying wire as shown. To which letter will the compass point?

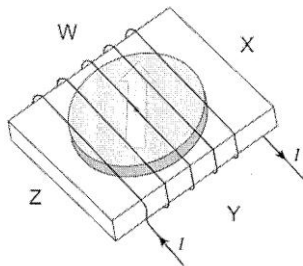

9. Which direction would the current be flowing if the compasses formed the arrangement as shown below?

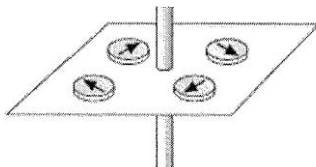

10. Which of the four letters indicates the direction of the magnetic field when current flows in the solenoid below?

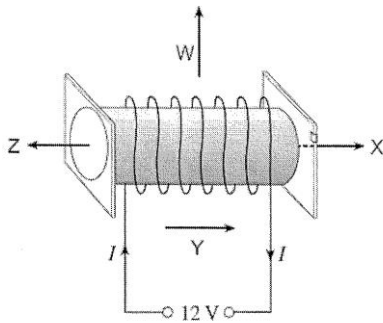

11. Use the right-hand-grip rule to determine the direction of the magnetic field at point X in the following diagrams.

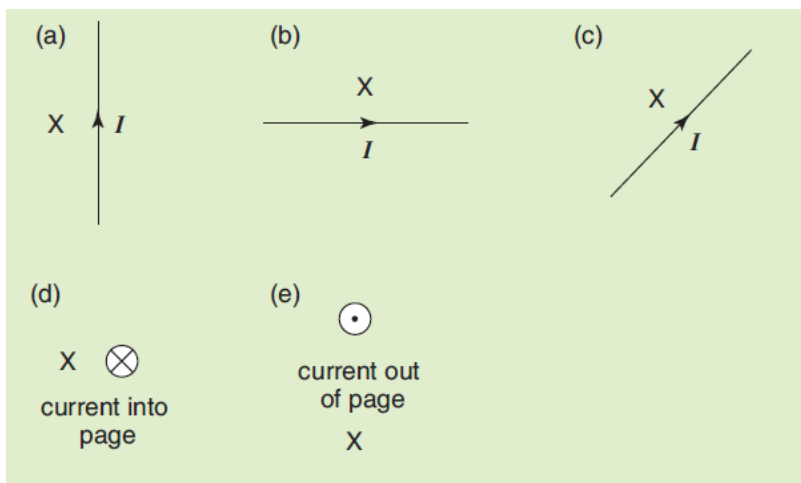

12. Copy the following diagrams and use the righthand-grip rule and the direction of the magnetic field at X to determine the direction of the current in the wire in each case.

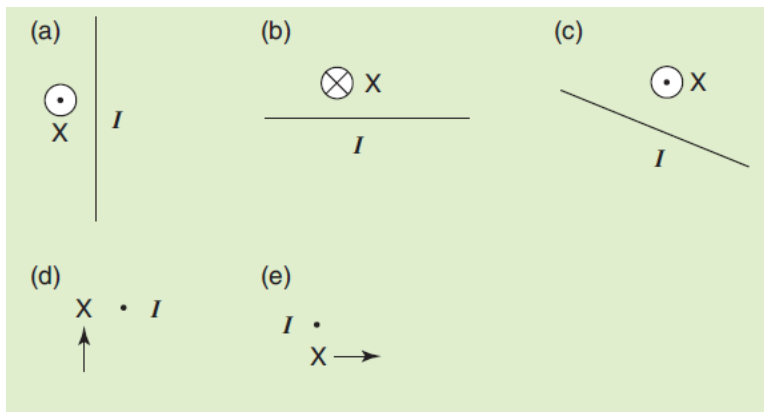

13. Use the right-hand-grip rule to determine the direction of the magnetic field at W, X, Y, Z in the following diagrams. Figure (a) represents a circular loop of wire with a current and figure (b) represents a solenoid.

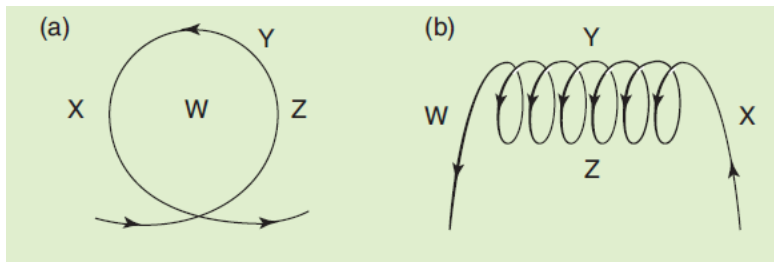

14. a) Find direction of the current in the two straight conductors, S and T, in the diagram below.

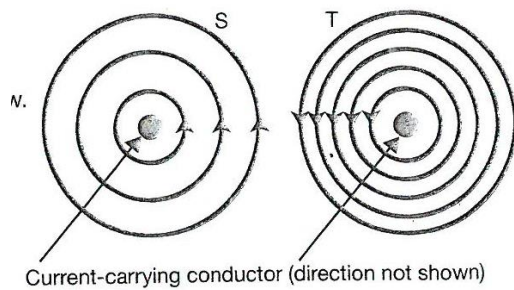

b) The above diagram has been drawn incorrectly. Identify the way(s) in which it is incorrect. Justify your answer.

15. Draw the shape of the magnetic field between the pairs of magnets shown.

(i)



(ii)



16. Identify the direction of the current in each of the conductors shown in the diagrams below. The magnetic fields near the conductors are shown. Write your answers in the boxes and show it on the diagrams.

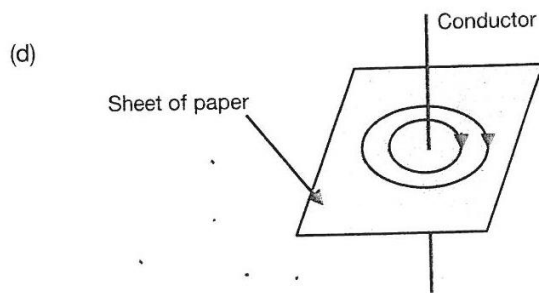
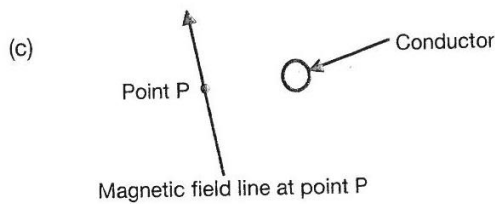
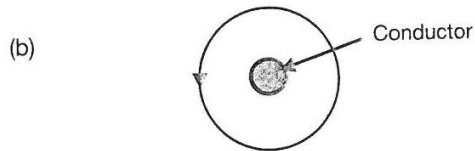
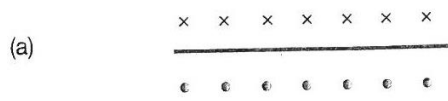

17. Find polarity of the voltage connected to the solenoid.

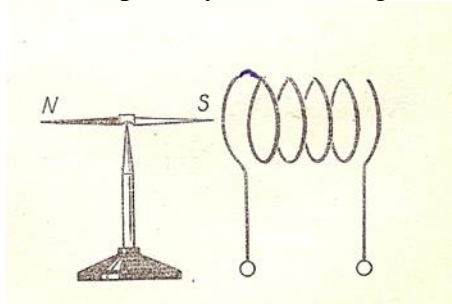

18. A cross-section through a solenoid carrying an electric current directed as shown. What is direction of the magnetic field at points X, Y, Z?

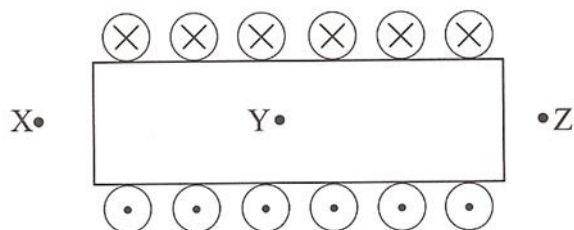

19. Cross-section of the solenoid with the current shown. Indicate which end of the solenoid becomes the north pole and which south. Explain why solenoid becomes an electromagnet. Draw 2 lines of magnetic field.

