

**Area of study 1 – Electric power**

**Question 1**

Figure 1 shows a solenoid connected to a battery. At points P and Q, Earth has a horizontal magnetic field comparable in size to that produced by the solenoid at these points.

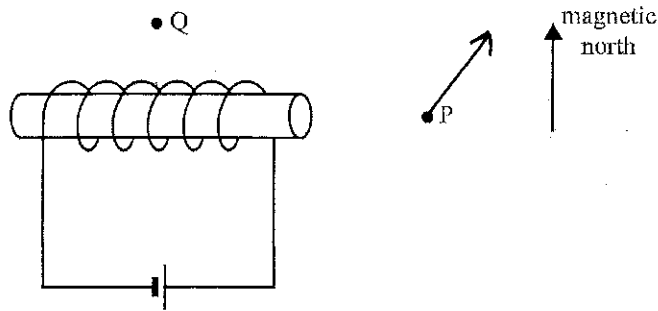

**Figure 1**

- a. Draw an arrow at point P to indicate the direction of the magnetic field at that point. **42%** 1 mark
- b. Roger has a small magnet that is free to rotate about an axis at its centre. This is shown in Figure 2. In this question, ignore the effect of Earth's magnetic field. **47%**

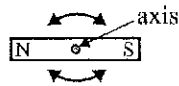

**Figure 2**

Roger places the magnet at point Q in Figure 1.

Identify which of the following best shows the orientation that the magnet will take. Write your answer in the box provided.

<b>A.</b>	<b>B.</b>	<b>C.</b>	<b>D.</b>	<b>E.</b>	<b>F.</b>

C

2 marks

**Question 4**

A farmer uses an AC motor to power an irrigation pump. The motor needs 900 V RMS AC input for the pump to operate correctly. When the motor is running with 900 V RMS AC, the motor draws 50 A RMS AC current.

- a. Calculate the power input to the motor when the pump is operating correctly. You may assume that the motor uses power just like a resistor. Give your answer in kilowatt. *85%*

$$P = VI$$

---



---



---

45 kW

2 marks

To supply electricity to the AC motor that drives the pump, a water-driven AC generator is installed at a waterfall some distance away from the pump. The generator provides current at a voltage of 1000 V RMS AC. The farmer uses two aluminium wires to link the generator to the pump, as shown in Figure 4. The wires have a total resistance of 7.0 Ω.

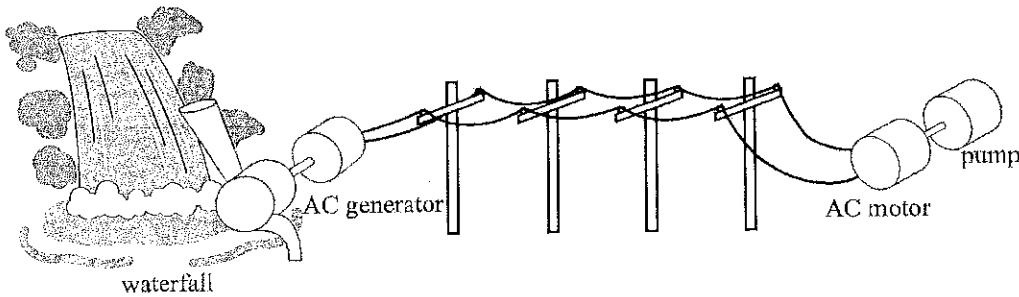

Figure 4

- b. The motor has a constant resistance of 18 Ω.

Calculate the current flowing in the aluminium connecting wires. *52% average 1.1*

$$I = \frac{V}{R_t} \quad R_t = 18 + 7 = 25 \Omega$$

---



---



---

40 A

2 marks

- c. Determine whether the pump will operate correctly. Support your conclusion with calculations. 39%

average 1.5

No, current required 50A, but as found in 4b  
current is only 40A

3 marks

- d. The farmer wishes to reduce the power losses in the electrical connections between the AC generator at the waterfall and the AC motor powering the irrigation pump. It is not possible to move the position of either the AC generator or the AC motor.

Identify and describe two different changes that would reduce the power losses between the AC generator and the AC motor. In your answer, you must also explain how each of the two changes you identified would reduce power losses.

3% average 2.0

first change Transformers at both ends

As a result for same power if  $V \uparrow$ ,  $I \downarrow$ , so  
 $P_{loss} \downarrow$  as  $P = I^2 R$

second change Reduce  $R_{lines}$  - thicker wires or smaller  $\rho$  (resistivity)

Smaller  $R \rightarrow$  smaller  $P_{loss}$  as  $P = I^2 R$

4 marks

- c. The students **halve** the speed of rotation of the generator. On the axes below, sketch the voltage signal that the AC generator will now produce. Label the voltage axis carefully with the correct numbers.

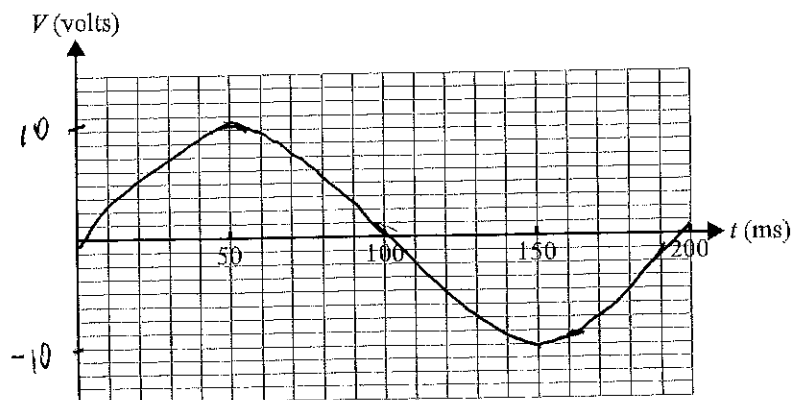

3 marks

### Question 6

Students are testing a transformer. The transformer is working correctly. The transformer has 600 turns in the primary coil and 150 turns in the secondary coil.

- a. The students attach the primary coil to a 20 V RMS AC power supply. *85%*  
Calculate the RMS voltage across the secondary coil.

$$\frac{150}{600} = \frac{V}{20}$$

---



---



---



---

5 V

1 mark

- b. The students now connect the primary coil of the transformer to a 20 V battery and find, after a short time, that there is no voltage across the secondary coil.

Explain why there is no voltage produced across the secondary coil. In your explanation, include a reference to the relevant physics principle. *25% average 0.7*

*Battery produces constant current. Since there will be no change in flux, no voltage will be induced*

2 marks

**Question 7**

Students are experimenting with a simple AC generator, as shown in Figure 6. It consists of a rectangular coil of  $n$  turns that rotates at a constant speed in a uniform magnetic field.

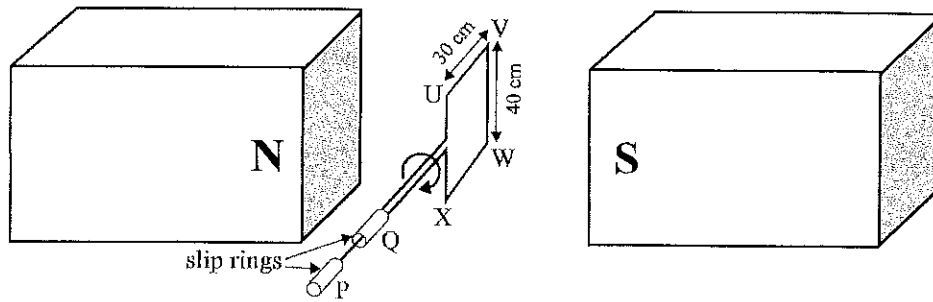

**Figure 6**

The uniform magnetic field in the region between the magnets is 0.030 T. The dimensions of the rectangular coil are 30 cm  $\times$  40 cm.

The coil is located completely within the uniform magnetic field of the two magnets.

The coil is rotating at a steady rate of 2 rotations per second.

- a. Describe how the magnetic flux through the rotating coil changes as the coil makes a complete rotation. Take the starting point of the rotation to be the position shown in Figure 6. You do not need to include any calculations or numbers in your answer. **25%**

---



---



---



---

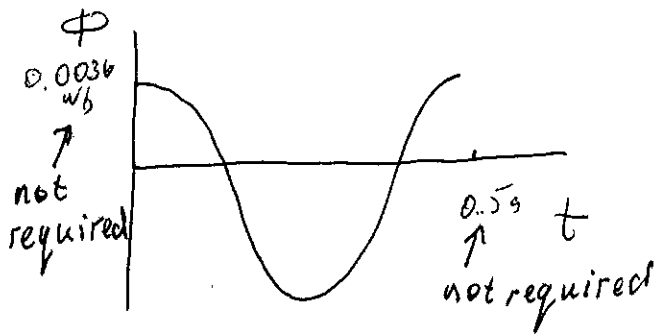

2 marks

**Question 8**

Figures 7a and 7b show a square loop being moved between the poles of a magnet. In the space between the poles there is a uniform magnetic field.

The loop moves at a steady speed from position 1 to position 3.

The loop is connected to a sensitive microammeter. The area of the loop is much less than the area of the magnetic field.

You may assume that the only magnetic field present is located directly between the north and south poles.

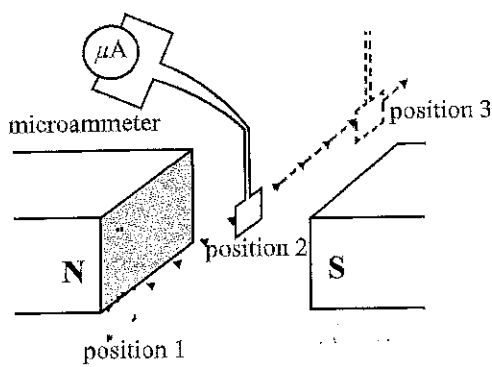

**Figure 7a**

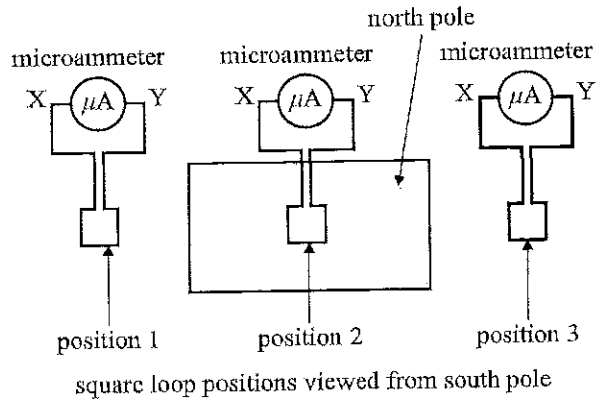

**Figure 7b**

a. Which of the following graphs best shows how the flux through the square loop varies with time as it moves from position 1 through to position 3? Write your answer in the box provided. **77%**

A.

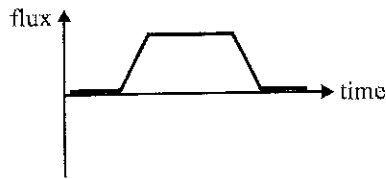

B.

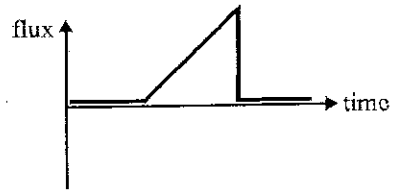

C.

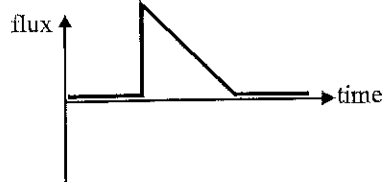

D.

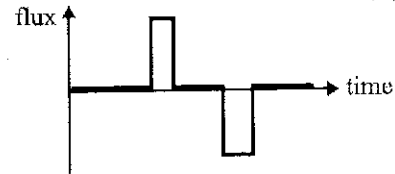

**A**

*[Handwritten scribbles]*

1 mark

- b. Which of the following graphs best shows how the magnitude of the emf in the square loop varies with time as it moves from position 1 through to position 3? Write your answer in the box provided. 74%

A.

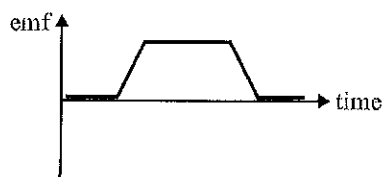

B.

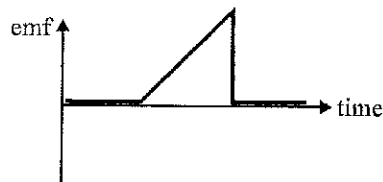

C.

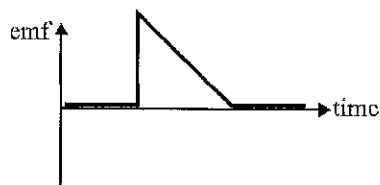

D.

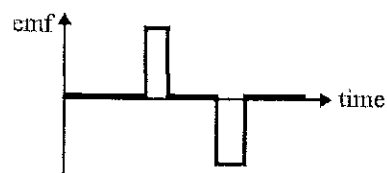

D

1 mark

- c. Describe the direction of the current in the square loop as it moves from position 2 to position 3, as viewed from the south pole (see Figure 7b). You may use a sketch in your answer. Explain the reasons for your answer. 13%

average 1.0

Anticlockwise. Flux ( $\vec{B}$ ) is out of the page and  $\downarrow$ .  
 So induced  $\vec{B}$  is out of the page. Using RHR -  
 current flows anticlockwise

3 marks

END OF AREA OF STUDY 1  
 SECTION A – continued  
 TURN OVER

1. The first part of the document discusses the importance of maintaining accurate records of all transactions and activities. It emphasizes the need for transparency and accountability in financial reporting.

2. The second part of the document outlines the various methods and techniques used to collect and analyze data. It includes a detailed description of the experimental procedures and the statistical tools employed.

3. The third part of the document presents the results of the study, showing the trends and patterns observed in the data. It includes several tables and graphs to illustrate the findings.

4. The final part of the document discusses the implications of the results and provides recommendations for future research. It also includes a conclusion summarizing the key points of the study.



**Question 15 (7 marks)**

Students are experimenting with an ideal transformer. The circuit is shown in Figure 19.

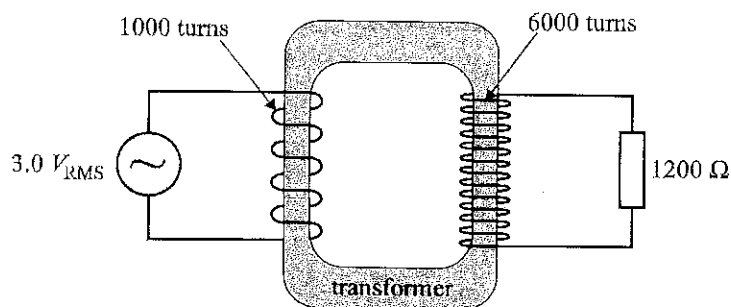
**Figure 19**

The primary coil has 1000 turns; the secondary coil has 6000 turns. There is a  $1200 \Omega$  resistor in the secondary circuit. A  $3.0 V_{\text{RMS}}$  AC power supply is connected across the primary coil.

- a. Calculate the RMS voltage across the resistor. **77%**

1 mark

$$\frac{N_2}{N_1} = \frac{V_2}{V_1} \quad \frac{6000}{1000} = \frac{V_2}{3}$$

18 V

- b. Calculate the peak voltage across the resistor. ~~58%~~ **76%**

1 mark

$$V = 18\sqrt{2}$$

25.5 V

- c. Calculate the power dissipated in the resistor. **58%**

2 marks

$$P = \frac{V^2}{R} = \frac{18^2}{1200}$$

0.27 W

The students now modify the circuit, and connect a 3.0 V DC battery and a switch in the primary circuit, as shown in Figure 20.

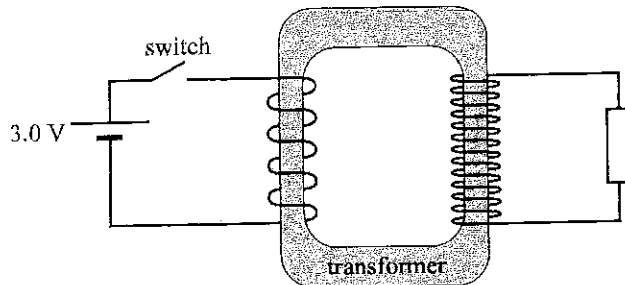

Figure 20

- d. The students have been asked to observe the current in the resistor as the switch is closed. Before the switch is closed, there is no current in the resistor. This does not surprise them. When the switch is closed, there is a very short pulse of current in the resistor. When the switch remains closed, there is no current in the resistor.

Explain why there is a short pulse of current as the switch is closed and why there is no current in the resistor as the switch remains closed. No numbers are required in your answer, but you should refer to the relevant law of physics.

3 marks

Switch closed  $\rightarrow$  sudden increase in the current, so change in flux. According to Faraday's law voltage and so current will be induced in the secondary coil.

Switch remains closed  $\rightarrow$  no change in current  $\rightarrow$  no change in flux  $\rightarrow$  no change in flux  $\rightarrow$  no induced voltage and current in secondary.

**Question 16 (6 marks)**

A diagram of a DC motor is shown in Figure 21.

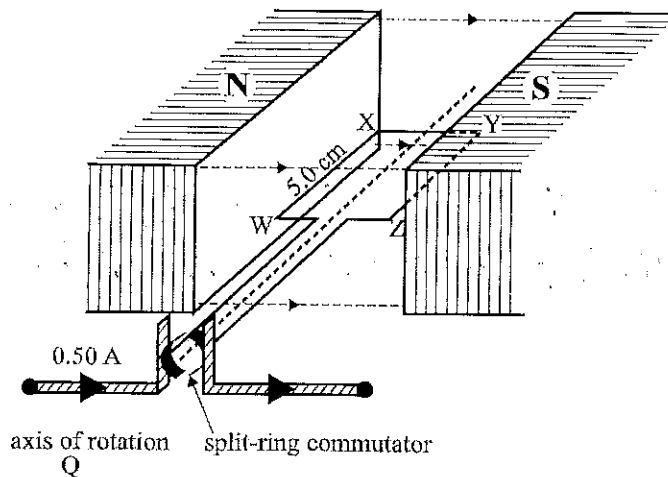

Figure 21

- a. The motor is operating and the rectangular coil is rotating about the axis of rotation. Mary views the operating motor from point Q.

Is the direction of rotation clockwise or anticlockwise? Give a reason for your answer.

50%

2 marks

~~Anticlockwise~~ Anticlockwise according to RHR  
 ( $\vec{B}$  to the right, current from W to X, force on WX down)

- b. While in the position shown in the diagram, a current of 0.50 A is flowing in the rotating coil. The coil has 20 turns and the magnetic field at the side labelled WX has a strength of 500 mT. The side WX has a length of 5.0 cm.

Calculate the magnitude of the force on the side WX.

66%

2 marks

$$F = nBil = 20 \times 0.5 \times 0.5 \times 0.05$$

0.25 N

- c. There is a split-ring commutator fitted to the motor. Mary suggests that the split-ring commutator causes a lot of friction on the motor, and that the motor would rotate faster if the split-ring commutator were removed and, instead, slip-rings were used to connect the input DC current to the rotating coil. Would this change improve the operation of the motor? Give reasons for your answer. 40% 2 marks

*No. Coil will turn 90° and stop as slip rings will not reverse current in the coil.*

**Question 17 (11 marks)**

Students conduct an experiment that is shown in Figure 22. An aluminium ring is made to oscillate vertically between point A and point B. Point C is the midpoint between A and B. A strong, small bar magnet is fixed at the centre of the oscillation, as shown in Figure 22.

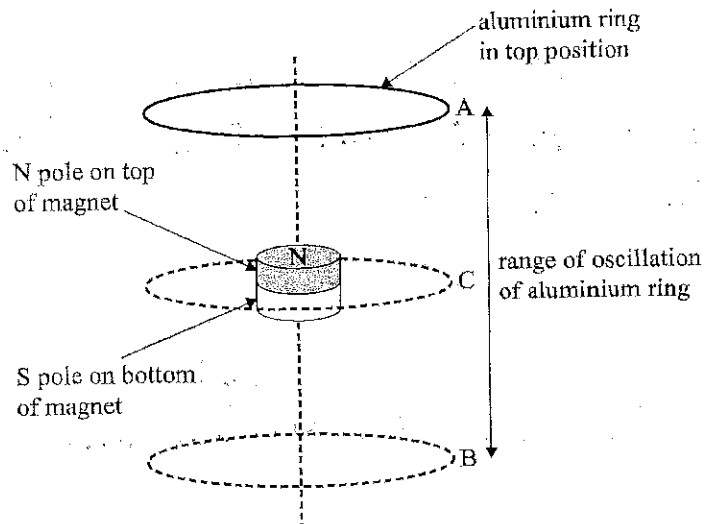

Figure 22

The vertical dashed line goes through the centre of the aluminium ring and also through the centre of the bar magnet in the diagram.

The magnetic flux through the aluminium ring is graphed as a function of time in the graph shown in Figure 23.

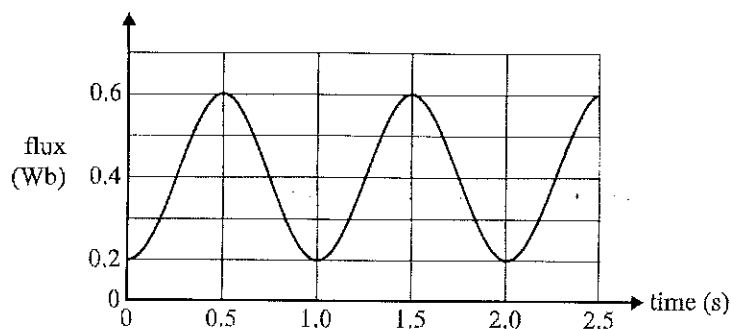

Figure 23

- a. The resistance measured around the aluminium ring is  $0.1 \Omega$ .

Calculate the average current flowing around the ring from time  $t = 1.0 \text{ s}$  to  $t = 1.5 \text{ s}$ .

49%

3 marks

$$E_{\text{av}} = -N \frac{\Delta \Phi}{\Delta t} = 0.8 \text{ V} \quad I = \frac{E}{R} = 8 \text{ A}$$

8 A

- b. Use information from the graph in Figure 23 to specify the time(s) after  $t = 0 \text{ s}$  and before  $t = 2.0 \text{ s}$  when the emf around the ring will be zero.

41%

2 marks

0.5, 1.0, 1.5 - gradient of flux = 0

- c. When the ring is moving downwards towards the N pole of the magnet, a current flows around the ring.  
Use a sketch or words to describe the direction of this current when viewed from above. Explain your answer carefully. *13% average 1.1*

4 marks

*Clockwise from above. Flux ( $\vec{B}$ ) is up and increases, so induced magnetic field down to oppose change in flux. RHR gives direction of current ~~anticlockwise~~ clockwise from above.*

- d. Use information from the graph in Figure 23 to complete the table below, showing the times (between  $t = 0$  s and  $t = 2.5$  s) when the aluminium ring is located at point A, point B and point C, as shown in Figure 22.

At  $t = 0$  s, the ring is at point A.

*21% average 0.5*

2 marks

Position of ring	Time(s)
at point A	0 2.0
at point C	<del>when</del> 0.5 1.5 (2.5)
at point B	1.0

*Flux is maximum at C.  
At A and B - minimum,  
starting from A*

### Area of study – Electric power

#### Question 12 (2 marks)

Figure 23 shows a coil placed next to a straight wire. When both the coil and the wire carry an electric current, there is a force exerted on the wire. The directions of the currents are shown by arrows on the diagram. The point X lies on the axis of the coil.

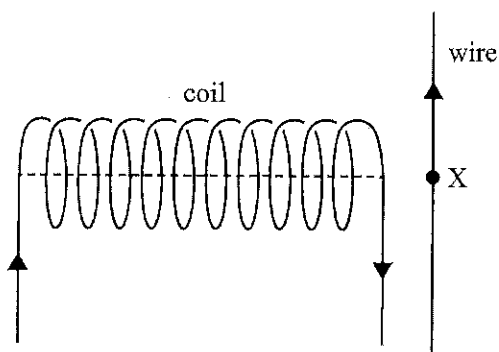

Figure 23

- a. Which one of the following best describes the direction of the **magnetic field of the coil** at point X? 1 mark
- |         |                    |                  |     |
|---------|--------------------|------------------|-----|
| A. left | B. right           | C. up            | 51% |
| D. down | E. out of the page | F. into the page |     |

A

- b. Which one of the following best describes the direction of the **force on the wire** at point X? 66% 1 mark
- |         |                    |                  |
|---------|--------------------|------------------|
| A. left | B. right           | C. up            |
| D. down | E. out of the page | F. into the page |

E

DO NOT WRITE IN THIS AREA

**Question 13 (7 marks)**

A horizontal square conducting metal loop of one turn is placed in a uniform, steady magnetic field between two poles of an electromagnet, as shown in Figure 24. The plane of the loop is perpendicular to the magnetic field.

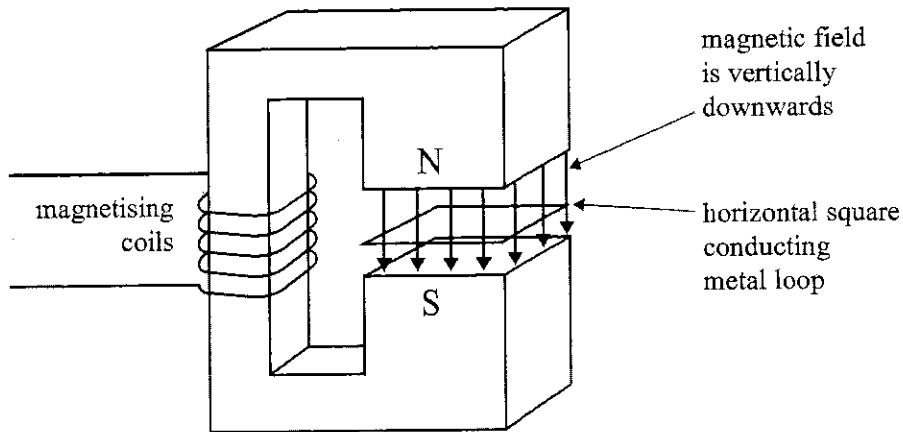

**Figure 24**

a. Students discuss different methods of causing a current to flow in the loop. 33%

Choose **one or more** of the following options that would cause a current to flow in the loop.

1 mark

- A. moving the loop directly upwards in the field towards the N pole
- B. moving the loop sideways (to the left) but keeping it completely inside the field
- C. moving the loop sideways (to the right) so that it moves out of the magnetic field
- D. rotating the loop about a horizontal axis

C, D

b. The uniform field of the magnet between its poles is initially equal to 0.050 T. The current in the electromagnet is then adjusted so that the field reduces to zero in 10 ms.

An average current of 0.020 A flows in the loop. The area of the loop is 0.080 m<sup>2</sup>.

Calculate the resistance of the loop. Show your working. 50%

3 marks

$$\mathcal{E} = \frac{0.05 \times 0.08}{0.01} = 0.4 \text{ V} \quad R = \frac{V}{I}$$

---



---



---

20  $\Omega$

DO NOT WRITE IN THIS AREA



- c. The magnetic field is reduced to zero.

On Figure 25, indicate the direction of the resulting induced current in the loop. Explain your reasoning.

2 1/2%

3 marks

average 1.1

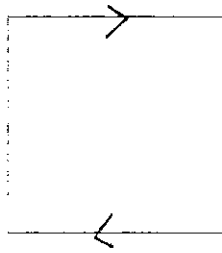

loop as viewed from above

Figure 25

Flux down and decreasing  $\rightarrow$  induced magnetic field will be down to oppose change in flux.  
Using RHR current flows clockwise

DO NOT WRITE IN THIS AREA

**Question 14** (3 marks)

An ideal transformer has 130 turns in the primary coil and 5200 turns in the secondary coil.

- a. A DC voltage signal of 12 V is connected to the primary coil.

State the value of the steady voltage at the output of the secondary coil. 30 %

1 mark

DC input

0 V

- b. An AC voltage signal is then connected to the primary coil and an AC RMS voltage of 400 V appears at the output of the secondary coil.

Calculate the **peak** value of the voltage at the input of the primary coil. 53 %

2 marks

$$\frac{130}{5200} = \frac{V_{in}}{400} \quad V_{in} = 10V$$

$$V_{peak} = 10\sqrt{2}$$

14.1 V

DO NOT WRITE IN THIS AREA

**Question 15** (6 marks)

Jemima is planning to operate an electric light globe in a building some distance from her house. To do this, she connects two long wires from a variable voltage DC power supply in the house to an electric light globe in the building.

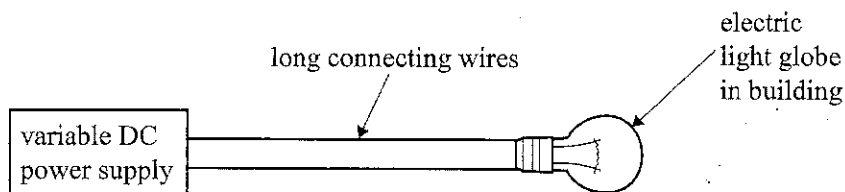

**Figure 26**  
not to scale

The wires have a total resistance of  $5.0 \Omega$ . The DC power supply produces a constant output voltage of  $13 \text{ V}$ . The light globe in the building is designed to operate at  $6.0 \text{ V}$ . Assume that its resistance is a constant  $1.5 \Omega$ .

When Jemima switches on the circuit, she measures the voltage at the light globe to be only  $3.0 \text{ V}$ .

- a. Calculate the voltage loss in the long connecting wires. **74%** 1 mark

$$13 - 3$$

10 V

- b. Calculate the power output of the light globe at this voltage. **65%** 1 mark

$$\frac{3^2}{1.5}$$

6 W

- c. Calculate the current flowing in the long connecting wires. **59%** 1 mark

$$I = \frac{V}{R} = \frac{10}{5}$$

2 A

- d. Jemima knows that more brightness can be achieved if she sets the DC power supply to a higher constant voltage. However, she also knows that it is unwise to run the light globe at greater than 6.0 V as it will probably fail.

Calculate the greatest voltage that Jemima can set the DC power supply at, without exceeding 6.0 V across the light globe in the building. Show your working. 40%

3 marks

$$I = \frac{P}{V} = 4 \quad V = 4 \times 6.5$$

$$V_{\text{loss}} = 4 \times 5 = 20 \text{ V}$$

$$V_{\text{total}} = 20 + 6$$

26	V
----	---

**Question 16** (4 marks)

Efficient transmission of electric power over long distances often involves the use of step-up and step-down transformers. 8% average 1.7

Outline how the use of these transformers reduces transmission losses. Include relevant physics formulas.

Amount of power to be transmitted is fixed.

Step-up transformer increases voltage ~~and~~ and so decrease current.

Less current meant less power loss in the lines  $P = I^2 R$

Step-down transformer reduces voltage to the level appropriate for end user

**Question 17 (9 marks)**

A model DC motor using permanent magnets is shown in Figure 27. The coil of the motor is formed from 75 turns of wire. Each turn is rectangular, having a length of 40 cm (sides WX and YZ) and a width of 15 cm (sides XY and WZ).

The magnetic field is uniform and has a value of 0.020 T. The coil can rotate freely between the magnets. The axis of the motor and the direction of the magnetic field are shown.

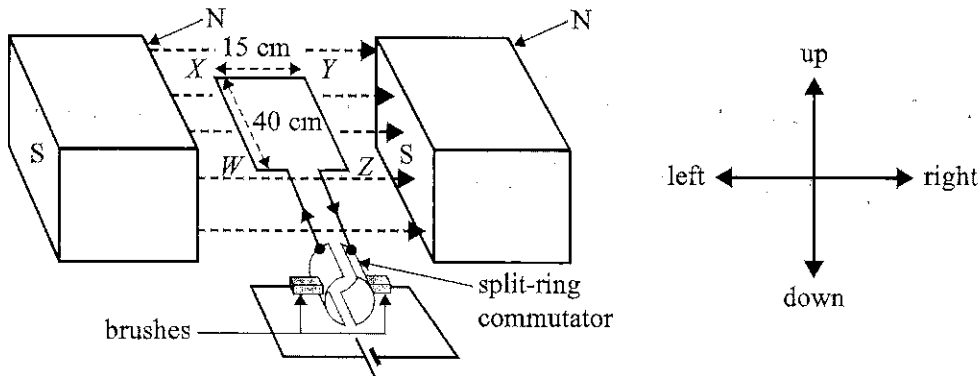

**Figure 27**

- a. In the table below, describe the direction of the forces on all four sides of the coil. Assume that the coil is in the horizontal position and the current direction is as shown in Figure 27. Use the words 'up', 'down', 'left', 'right' or 'no force'. *67%*

2 marks

Side	Force direction
WX	↓
XY	0
YZ	↑
ZW	0

- b. What is the magnitude of the force on the side WX of the 75-turn coil when the coil is horizontal and the current is 2.0 A? *68%*

2 marks

$$F = n I l B = 75 \times 2.0 \times 0.4 \times 0.02$$

1.2 N

- c. The motor is switched on when the coil is stationary in the horizontal position, and the coil starts to rotate.

Explain why this rotation occurs. 36%

2 marks

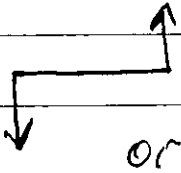

The forces on opposite side of the coil are in opposite directions, so a torque produced

- d. As the coil rotates from its starting position, it travels through a vertical position, when its plane is perpendicular to the magnetic field. 73%

In the table below, indicate the direction of the current in the side WX (if there is a current) at the three positions listed. Use only the following directions:

- from W to X
- from X to W
- no current

3 marks

Position	Current in side WX
before the vertical position	W → X
at the vertical position	0
after the vertical position	X → W

DO NOT WRITE IN THIS AREA

**Question 18** (7 marks)

A sketch of a small model generator is shown in Figure 28. The magnetic field is supplied by two permanent magnets. The output of the generator is fitted with slip rings and is connected to an oscilloscope.

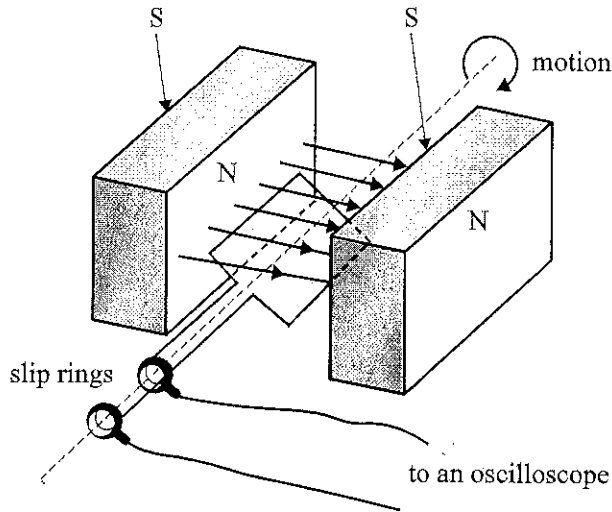

Figure 28

- a. The display on the oscilloscope shows an AC signal.

8% average 1.1

Explain why the signal is AC rather than DC.

3 marks

The spinning loop produces an AC signal.

Slip rings provide a constant connection, so output to the oscilloscope will be AC.

A split-ring commutator needed to provide DC output.

- b. The coil of the generator makes one half turn ( $180^\circ$ ) every 25 ms.

Calculate the frequency of the AC signal produced by the generator. 51%

2 marks

$$\text{period } T = 2 \times 25 \text{ ms} = 0.05 \text{ s}$$

$$f = \frac{1}{T}$$

20 Hz

- c. The speed of rotation of the coil is increased so that it completes one half turn every 10 ms.

State whether this will increase, decrease or not change the magnitude of the voltage output of the generator. Give a reason for your answer. 44%

2 marks

↑ ~~the~~ Rate of change of flux will increase therefore output voltage increases.

$$E = \frac{\Delta \Phi}{\Delta t} \quad \text{or} \quad \text{If } \Delta t \downarrow \rightarrow E \uparrow$$

DO NOT WRITE IN THIS AREA



## Area of study – Electric power

### Question 12 (10 marks)

Students have a model that can be used as a motor or generator, depending on the connections used.

The magnets provide a uniform magnetic field of  $2.0 \times 10^{-3}$  tesla.

EFGH is a square coil of each side length 4.0 cm with 10 turns.

A 6.0 V battery and an ammeter are connected to the shaft through a commutator.

This is shown in Figure 12.

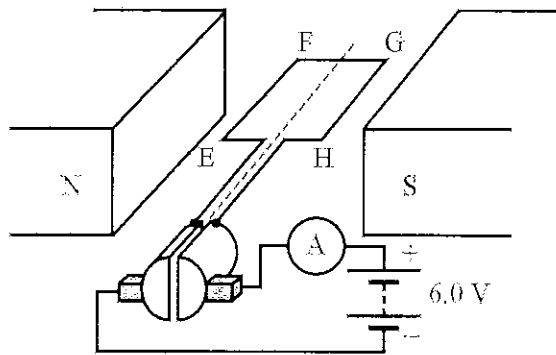

Figure 12

- a. The ammeter shows a current of 4.0 A.

53%

With the coil horizontal as shown in Figure 12, what is the force on the side EF? Give the magnitude and direction (up, down, left, right). Show your working.

3 marks

$$F = nBI\ell = 10 \times 2 \times 10^{-3} \times 4 \times 0.04$$

Direction from RHR

Magnitude  $3.2 \times 10^{-3}$  N

0.0032

Direction



The model is now set up as a DC generator, with the output connected to a voltmeter and oscilloscope via a commutator, as shown in Figure 13, with the same coil of side length 4.0 cm and 10 turns, and a uniform magnetic field of  $2.0 \times 10^{-3}$  tesla.

The shaft is rotated by hand.

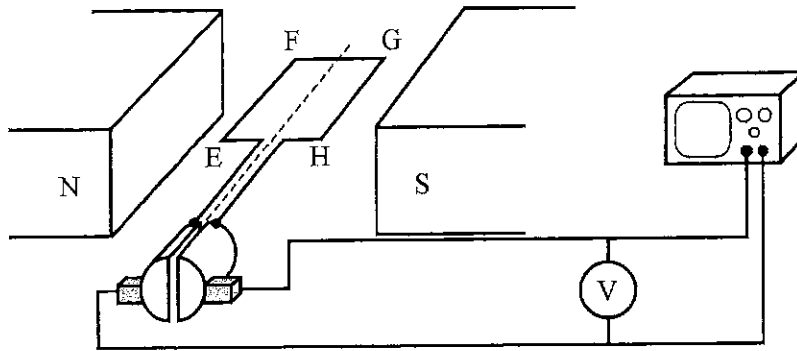
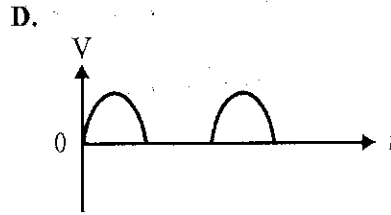
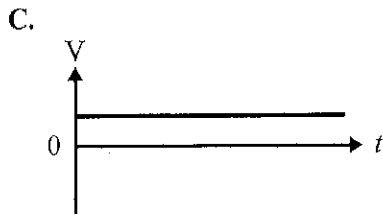
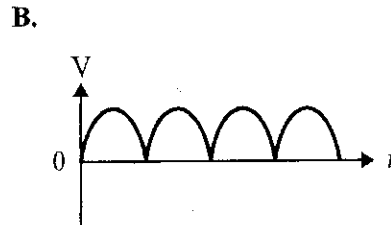
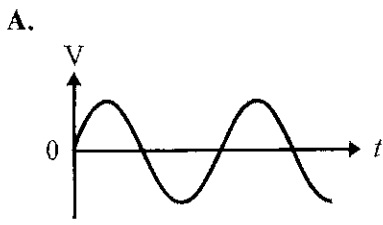

Figure 13

- b. Which one of the following graphs (A.–D.) best shows the voltage output as viewed on the oscilloscope as the coil rotates steadily? (At  $t = 0$ , the coil is horizontal, as shown in Figure 13.)

1 mark

80%



B

- c. The shaft and coil make two complete revolutions per second. *33% average 1.3*

Calculate the magnitude of the average voltage as shown on the voltmeter during one-quarter revolution. Show your working.

3 marks

$$\mathcal{E} = \frac{nBA}{t}$$

$$\mathcal{E} = \frac{10 \times 2 \times 10^{-2} \times (0.04)^2}{0.125}$$

0.26 mV

- d. The students wish to convert this DC generator into an AC generator. *16% average 1.4*

Describe the change or changes the student would have to make to achieve this. Explain your answer. 3 marks

*Replace split-ring commutator with slip rings.*

*Slip rings maintain constant connection and take AC current ~~prod~~ generated in the coil without changes.*

**Question 13 (8 marks)**

To study electromagnetic induction, students pass a square loop at constant speed through the pole pieces of a magnet, as shown in Figure 14a. Figure 14b shows the experimental set-up as viewed from above. The axes below indicate the same distances as shown in Figure 14b.

In answering Question 14, you do not have to include any calculations or values on the axes.

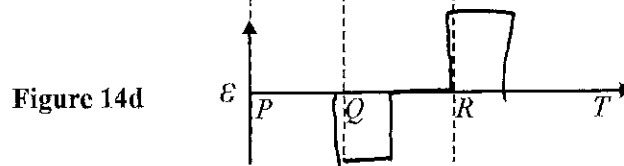
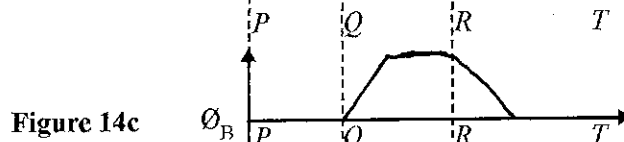
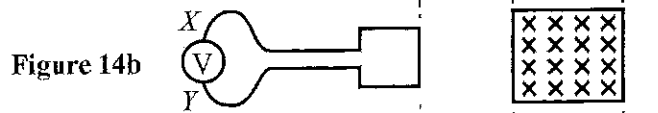
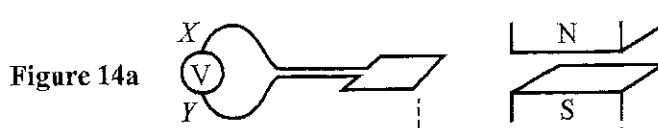

- a. On the axes in Figure 14c, sketch the magnetic flux as the front edge of the loop passes from  $P$  to  $T$ . 2 marks
- b. On the axes in Figure 14d, sketch the emf, as measured by the voltmeter, as the front edge of the loop passes from  $P$  to  $T$ . 2 marks

11%

34%

- c. Determine the direction of the current through the volimeter as the loop enters the magnetic field. Write  $X$  to  $Y$  or  $Y$  to  $X$  in the answer box below. Explain how you determined this in terms of Lenz's Law.

15% average 1.8

4 marks

$B$  down and increasing.

Induced  $B$  up.

RHG gives  $X$  to  $Y$

$X \rightarrow Y$

10/10/10

**Question 13** (4 marks)

A 3.0 m long, vertical, copper lightning conductor is located in a region where Earth's magnetic field is horizontal and pointing north. A current of 2000 A flows down the conductor to Earth during an electrical storm. Force detectors measure a force on the lightning conductor of 0.32 N.

- a. Calculate the magnitude of Earth's magnetic field acting on the lightning conductor. *80%* 2 marks

$$F = BIl$$

$$5.3 \times 10^{-5} \text{ T}$$

- b. Which one of the following (A.–E.) is the best description of the direction of the magnetic force acting on the lightning conductor? Explain your answer. *41%* 2 marks

- A. north
- B. south
- C. east
- D. west
- E. vertically up
- F. vertically down

C

RHSR

DO NOT WRITE IN THIS AREA

**Question 14** (5 marks)

Students build a simple electric motor, as shown in Figure 18.

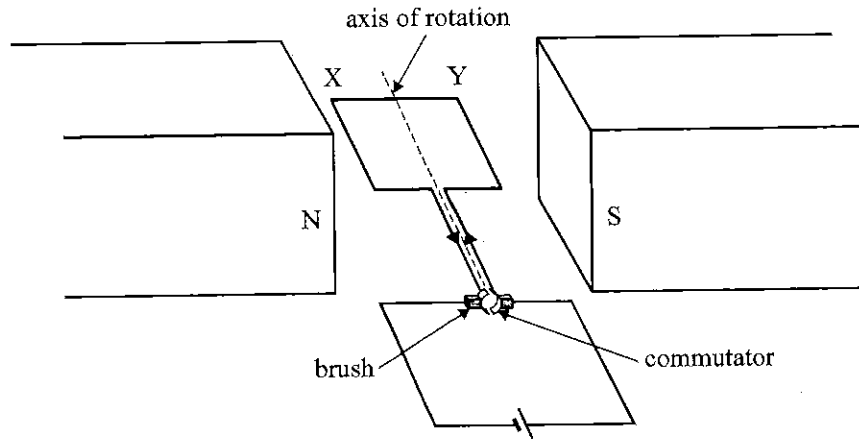

**Figure 18**

- a. At what position(s) (A.–D.) of the rotating coil is the magnetic force on the side XY zero? One or more answers may be selected. 40% 1 mark
- A. horizontal with the current as shown in Figure 18
  - B. horizontal with the current in the opposite direction to that shown in Figure 18
  - C. vertical
  - D. at all orientations of the coil

A, B

- b. The students discover that the motor starts moving more easily with the coil in some orientations than in others. 18% average 0.6 2 marks
- Explain the best orientation(s) for starting the motor to move from rest.

Coil horizontal  
 Turning effect is maximum (torque max) ~~force~~  
 force

DO NOT WRITE IN THIS AREA



- c. To increase the speed of rotation of the motor, the students suggest a number of improvements. Which suggested improvement(s) (A.–D.) is likely to increase the speed of rotation of the coil? One or more answers may be selected. Explain your answer.

34%

2 marks

- A. increase the battery voltage  
 B. replace the single coil of the motor with several turns  
 C. increase the resistance of the coil  
 D. reverse one of the poles of the permanent magnets

A, B
------

$$A: V \uparrow \rightarrow I \uparrow \rightarrow F = nBI\ell \uparrow$$

$$B: n \uparrow \rightarrow F = nBI\ell \uparrow$$

DO NOT WRITE IN THIS AREA

**Question 15** (5 marks)

A coil is wound around a cardboard cylinder, as shown in Figure 19. The cross-sectional area of the coil is  $0.0060 \text{ m}^2$ . There are 1000 turns in the coil (not all are shown in the diagram).

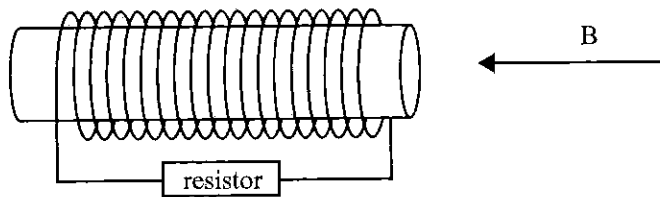
**Figure 19**

The axis of the coil is immersed in a uniform external magnetic field of strength  $0.0050 \text{ T}$  and its direction is shown by the arrow labelled  $B$  in Figure 19. *59%*

- a. Calculate the magnitude of the flux through the first turn of the coil. Include an appropriate unit. 2 marks

$$\Phi = BA = 0.005 \times 0.006$$

$$3.0 \times 10^{-5} \text{ Wb}$$

- b. The external magnetic field is now reduced to zero. This results in an emf in the coil. *19% average 1.1*

Describe the direction of the current in the resistor during this time (use the words 'left' and 'right').  
Give reasons for your answer. 3 marks

$$\Phi \leftarrow \text{and } \downarrow$$

$$\therefore B_{\text{ind}} \leftarrow$$

RHGR

Left

**Question 16** (12 marks)

Ruby and Max are investigating the transmission of electric power using a model system, as shown in Figure 20a. The circuit is shown in Figure 20b.

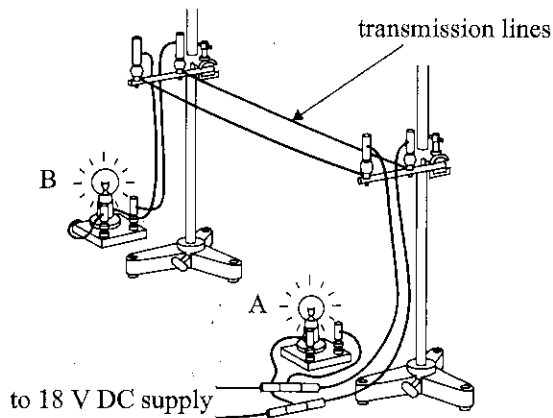

**Figure 20a**

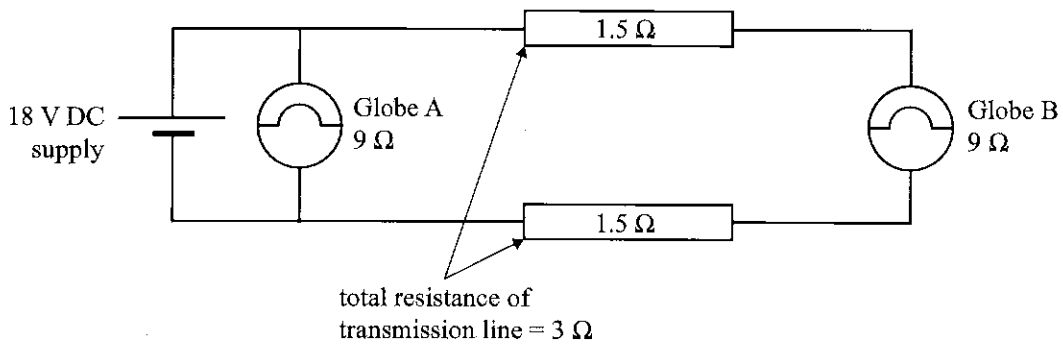

**Figure 20b**

Ruby and Max use an 18 V DC power supply, as shown in Figure 20b. The two transmission lines have a **total** resistance of 3.0 Ω. Assume that the resistance of the globes is constant at 9.0 Ω and that the other connecting wires have zero resistance.

- a. Calculate the power delivered to Globe A. 59 %

2 marks

$$P = \frac{V^2}{R} = \frac{18^2}{9}$$

---



---



---

36 W W

DO NOT WRITE IN THIS AREA

- b. Calculate the total voltage drop over the transmission lines. Show your working. *30%* 2 marks

$$R_{\text{total}} = 12 \Omega$$

*average 0.6*

$$I_{\text{total}} = \frac{18}{12} = 1.5 \text{ A}$$

$$V_{\text{line}} = 1.5 \times 3.0 = 4.5 \text{ V}$$

4.5 V

- c. Calculate the power delivered to Globe B. Show your working. *31%* 3 marks

$$V = 18 - 4.5 = 13.5 \text{ V}$$

*average 1.0*

$$P = \frac{V^2}{R} = \frac{13.5^2}{9}$$

20 W

Ruby has noticed that the voltage supply to houses is AC and that there are transformers involved (on street poles and at the fringes of the city). Ruby and Max next investigate the use of transformers to reduce power losses in transmission.

Ruby and Max have two transformers available – a 1:10 step-up transformer and a 10:1 step-down transformer.

- d. In the space provided below, redraw the circuit in Figure 20b with an 18 V AC supply and with the transformers correctly connected. Label the transformers as step up and step down. *13%* 2 marks

*average 0.7*

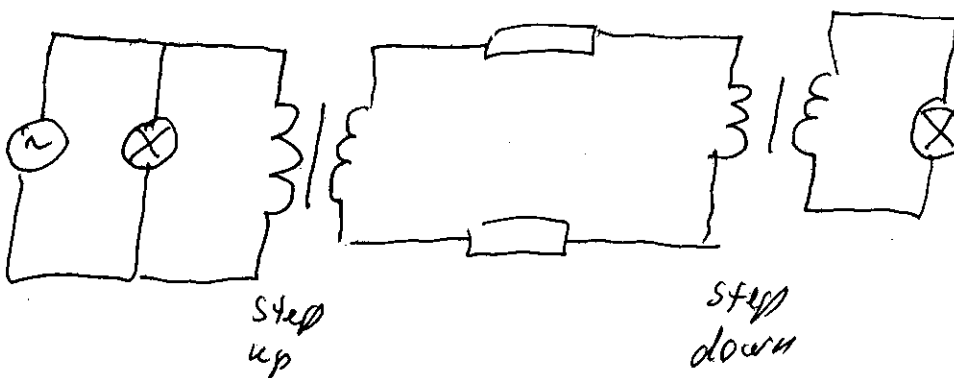

- e. Explain why the transformers would reduce the transmission losses. Your answer should include reference to key physics formulas and principles.

26%

3 marks

Transformers maintain const power

Power transmitted at high  $V$  and low  $I$ .

$$I \downarrow \rightarrow P_{\text{Loss}} = I^2 R \downarrow$$

DO NOT WRITE IN THIS AREA

**Question 17 (9 marks)**

Samira and Mark construct a simple alternator, as shown in Figure 21.

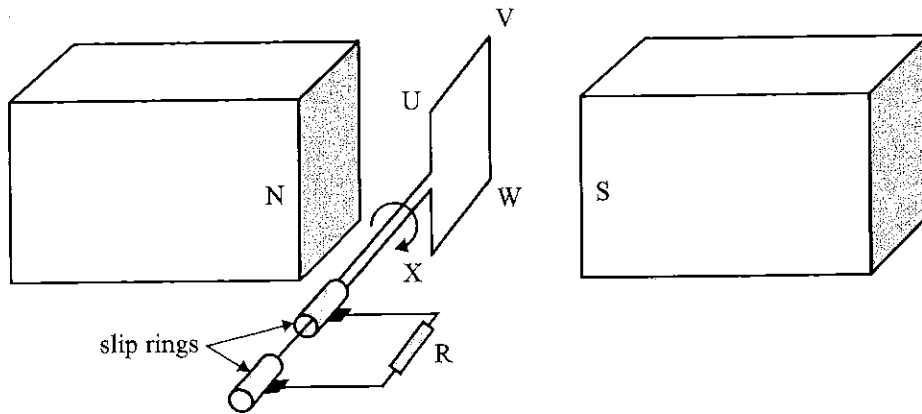

**Figure 21**

When the coil is rotating steadily, it takes 40 ms for each complete rotation and produces a peak emf of 3.5 V.

- a. Calculate the frequency of the AC emf. *68%* 2 marks

$$f = \frac{1}{T}$$

25 Hz

- b. Calculate the RMS value of the AC emf. *83%* 1 mark

$$\frac{V_p}{\sqrt{2}}$$

2.5 V

**DO NOT WRITE IN THIS AREA**

- c. Describe the orientation(s) of the rotating coil when the magnitude of the emf is at a maximum. Give reasons for your answer.

15%

2 marks

Horizontal

average 0.5

Rate of change of  $\Phi$  max

- d. To increase the magnitude of the emf produced by the alternator, Mark suggests making a number of changes to the alternator. His suggested changes are given in the table below.

35%

4 marks

In the spaces provided, indicate whether each suggestion will increase, decrease or have no effect on the emf of the alternator.

Suggested change	emf (increases, decreases, no effect)
Increase the number of turns in the rotating coil.	↑
Increase the frequency of rotation of the coil.	↑
Increase the strength of the permanent magnets.	↑
Reduce the resistance of the resistor R.	No effect

DO NOT WRITE IN THIS AREA

